



Type(s)

Project

Date

Notes

GENERAL INFORMATION

The Source 4WRD PAR and PARNel Fixture Bodies allow you to transform your Source 4WRD Color LED Engine into a beautiful softlight. Taking advantage of the great energy efficiency, cool operating temperatures, and no lamp changes, the Source 4WRD Color PAR and PARNel deliver an amazing output without compromise...or gel.

APPLICATIONS

- Houses of worship
- Universities and schools
- Hospitality
- Retail
- Exhibition centers
- Meeting rooms
- Clubs
- Cafeteriums

PRODUCT FEATURES

- Fixture bodies for use with Source 4WRD and Source 4WRD Color Light Engines
- Works just like a Source Four PAR or PARNel, using the same accessories
- 146 W at full output
- RGBA LED color array
- Uses same Source 4WRD Color LED retrofit as the Source 4WRD Color ellipsoidal

ORDERING INFORMATION

Source 4WRD Color PAR and PARNel Fixture Bodies

MODEL	DESCRIPTION	PART NUMBER	
S4WRDPAR	S4WRD PAR Fixture Body, Black	7067A1109	
S4WRD PARNel	S4WRD PARNel Fixture Body, Black	7067A1110	

Color Options: Fixture body ships standard in black. For additional colors please add -1 for white or -5 for silver.

Notes: Source 4WRD Color LED and C-clamp sold separately.

INCLUDED WITH SOURCE 4WRD PAR AND PARNEL FIXTURE BODIES

- Color frame
- Lenses:
 - PAR ships with AR coated flat lens (other lenses sold separately)
 - PARNel ships with PARNel lenses
- Diffusion (for use with Source 4WRD Color)



PRODUCT SPECIFICATIONS

Source

LED details	Nichia LEDs *Not Included*
Max lumens	5,565 (PAR), 5,014 (PARNel) w/ S4WRD Color
Lumens per watt	38 (PAR), 34 (PARNel)
L70 rating (hours to 70% output)	>60,000 hours*
Notes	S4WRD LED sold separately

*L70 value based on manufacturer's anticipated results

Color

Colors used	RGB-A (Red, Green, Blue and Amber)
Color temperature range	2,200–6,500 K
Calibrated array	Yes
Red shift	No

Optical

Beam angle range	PAR: 17–41° PARNel: 16–27°
Gate size	N/A
Aperture size	7 in
Pattern projection	No
Pattern size	N/A
Camera flicker control/Hz range	Yes, 1.2 kHz and 20 kHz
Notes	PAR ships with an AR coated flat lens. Additional PAR lenses sold separately. PARNel ships with PARNel lenses.

Control

Input method	DMX Control
Protocols	DMX/RDM via RJ45
Modes (Footprint)	1 (1=Intensity, 2=Red, 3=Green, 4=Blue, 5=Amber, 6=Strobe)
RDM configuration	Yes
UI type	7-segment address display, local level control via UI
Local control	Yes
Onboard presets	Yes, 12
Onboard sequences	Yes, 5
Onboard effects	No
FixtureLink support	Yes

Electrical

Voltage range	100–240 V (50–60 Hz)
Input method	Hardwired, 1 m cord, bare end or various connector options (120 V) Hardwired, 1 m cord, bare end (230 V)
Inrush	32 A (first half-cycle) at 120 V 60 A (first half-cycle) at 240 V
Fixtures per circuit	120 V: 10 (20 A switched circuit, R20 module or similar) 230 V: 10 fixtures per non-dimmed circuit (ER15AFR module)
Wattage (Typical/Standby)	146 W/3.0 W (120 V) 143 W/2.9 W (230 V)
Current draw	1.25 A at 120 V 0.67 A at 230 V

Thermal

Ambient operating temp	5°–40° C (41°–104° F)
Fan (controllable)	Yes (no)
Droop compensation	No
dB range	27 dBa (average at 1 m)
BTUs/hour	458 (120 V) 449 (230 V)

Physical

Materials	Die-cast aluminum
Color options	Black, white, silver or custom color
Mounting options	Yoke
IP rating	IP-20
Weight	PAR: 6.25 lb (2.83 kg) PARNel: 7.7 lb (3.49 kg)
Included accessories	Color frame
Notes	Includes S4WRD mounting post. Required S4WRD Color LED available separately.

Regulatory and Compliance

Approved regulatory standards	UL 1573 (complete luminaire) UL 1598C (retrofit kit) CSA C22.2 No. 166 (complete luminaire) CSA TIL B79-A (retrofit kit) CE Compliant
-------------------------------	---

PRODUCT FEATURES



LEND COLOR TO ANY SPACE

Millions of colors, from bold, saturated looks to pastel washes, all with soft edges.



USES YOUR EXISTING ACCESSORIES

Works just like a Source Four PAR and PARNel.



INTERCHANGEABLE WITH S4 PROFILES

You can interchange your Source 4WRD LED sources between your S4 profile fixtures and your Source 4WRD PAR and PARNel fixture bodies.

ADDITIONAL ORDERING INFORMATION

Accessories

MODEL	DESCRIPTION
S4WRDC	Source 4WRD Color (UL), black
407CF	Color frame (7.5") (included)
400SC	Safety cable
400CC	C-clamp
400-VNSP	Very Narrow Spot lens
400-NSP	Narrow Spot lens
400-MFL	Medium Flood lens
400-WFL	Wide Flood lens
400-LS4	Set of four Source Four PAR lenses (VNSP, NSP, MFL, WFL)
400-XWFL	Extra Wide Flood lens
400PTH3	Top hat, 3"
400PTH6	Top hat, 6"
400PHH	Half hat
400XBTH	Cross baffle top hat
400BD	Barn door
400L	Egg crate louver
400WB	Weighted base

NOTES ABOUT LED LUMINAIRES

All LED sources experience some lessening of light output and some color shift over time. LED output will vary with thermal conditions. Thermal conditions can be affected by ambient temperatures and orientation. Based on the LED manufacturer's B50 L70 specification, a Source 4WRD luminaire will achieve ~70% of its initial output after 60,000+ hours of typical usage. In individual situations, LEDs will be used for different durations and at different levels. This can eventually lead to minor alterations in color performance, necessitating slight adjustments to presets, cues or programs.

COLOR METRIC INFORMATION

SOURCE 4WRD COLOR PAR 3200 K

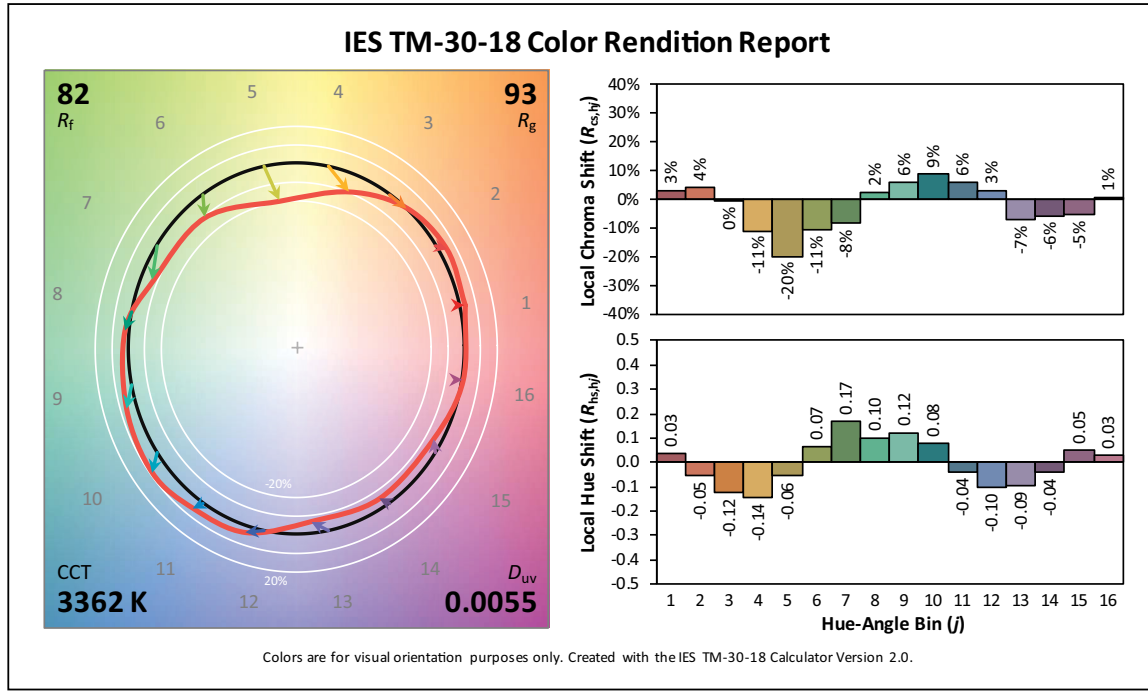

SOURCE 4WRD COLOR PAR 5600 K

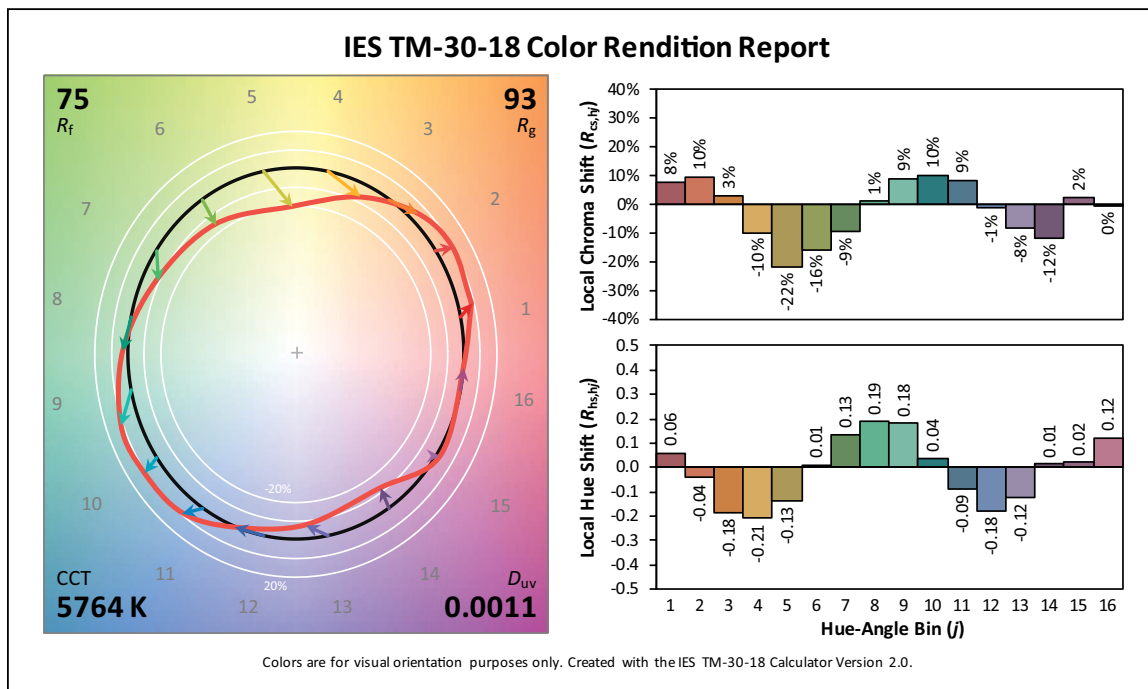

COLOR METRIC INFORMATION

SOURCE 4WRD COLOR PARNel 3200 K

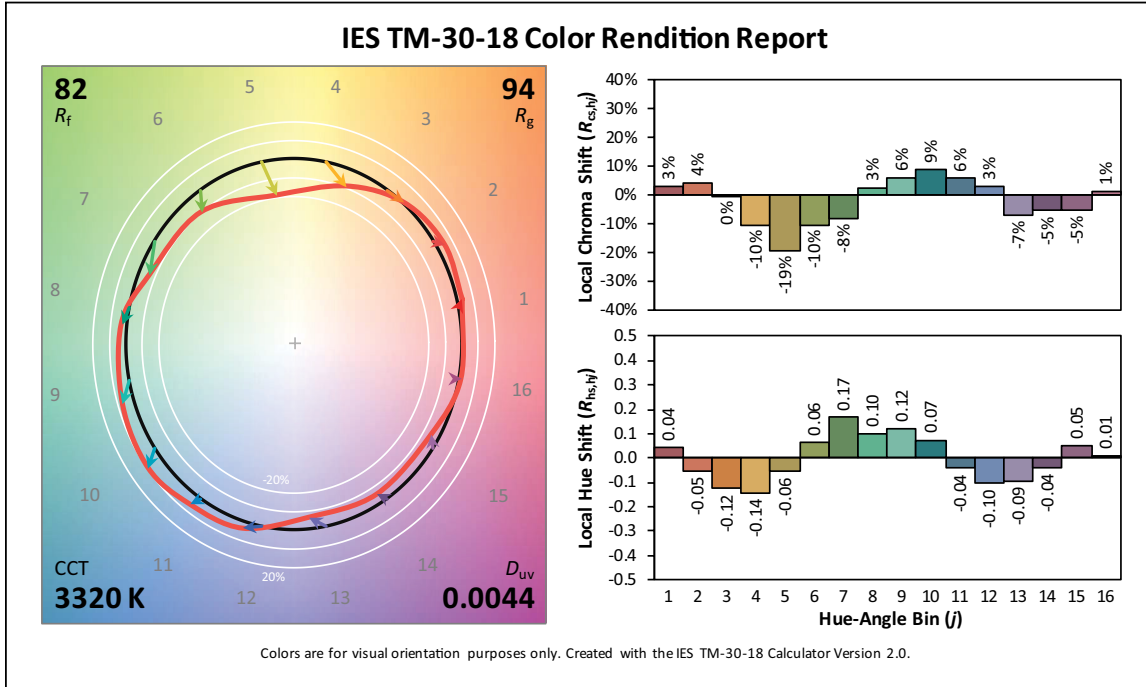

SOURCE 4WRD COLOR PARNel 5600 K

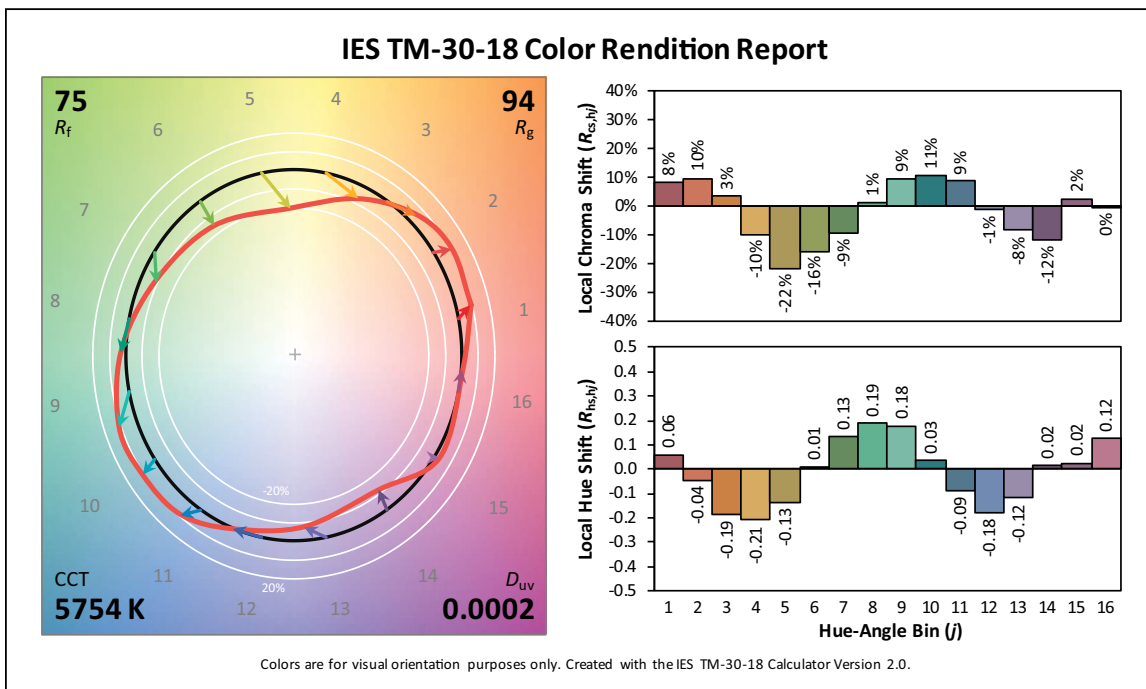

PHOTOMETRY INFORMATION

Source 4WRD Color PAR with AR Coated Flat Lens

Model	Degree	Candela	Field Lumens	Beam Lumens	Power Consumption	Lumens Per Watt
3200 K	33.9	45,243	4,004	1,833	102.1 W	39.2
5600 K	33.9	55,345	4,840	2,202	129.0 W	37.5
Full on	33.9	62,500	5,388	2,415	144.0 W	37.4

Metric conversions: For meters, multiply feet by 0.3048.
For lux, multiply footcandles by 10.76.

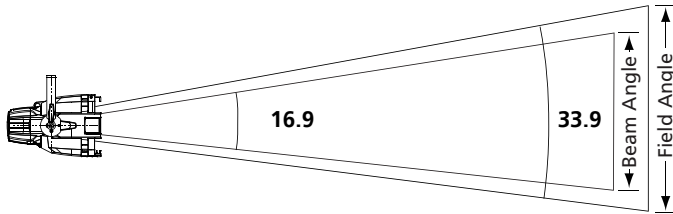

Throw Distance (d)	10 ft 3.0 m	15 ft 4.6 m	20 ft 6.1 m	25 ft 7.6 m	250.0 ft 76.2 m
Field Diameter	6.1 ft 1.9 m	9.1 ft 2.8 m	12.2 ft 3.7 m	15.2 ft 4.6 m	-
Illuminance (fc)	625	278	156	100	1
Illuminance (lux)	6,727	2,990	1682	1076	10.76

To determine center beam illumination in footcandles at any throw distance, divide candela by the throw distance squared.

For field diameter at any distance, multiply distance by 0.61.
For beam diameter at any distance, multiply by 0.298.

Source 4WRD Color PAR with VN5P Lens

Model	Degree	Candela	Field Lumens	Beam Lumens	Power Consumption	Lumens Per Watt
3200 K	34.7	40,836	3,674	1,651	102.1 W	36.0
5600 K	34.7	49,365	4,441	1,996	129.0 W	34.4
Full on	34.7	54,954	4,944	2,222	144.0 W	34.3

Metric conversions: For meters, multiply feet by 0.3048.
For lux, multiply footcandles by 10.76.

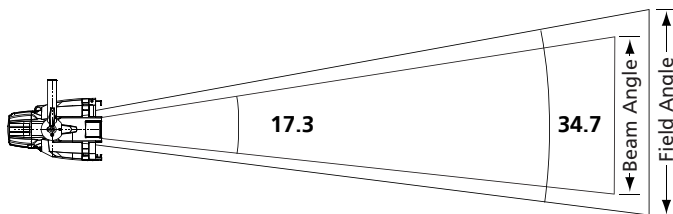

Throw Distance (d)	10 ft 3.0 m	15 ft 4.6 m	20 ft 6.1 m	25 ft 7.6 m	234.4 ft 71.5 m
Field Diameter	6.2 ft 1.9 m	9.4 ft 2.9 m	12.5 ft 3.8 m	15.6 ft 4.8 m	-
Illuminance (fc)	550	244	137	88	1
Illuminance (lux)	5,915	2,629	1479	946	10.76

To determine center beam illumination in footcandles at any throw distance, divide candela by the throw distance squared.

For field diameter at any distance, multiply distance by 0.625.
For beam diameter at any distance, multiply by 0.304.

Candela Plot

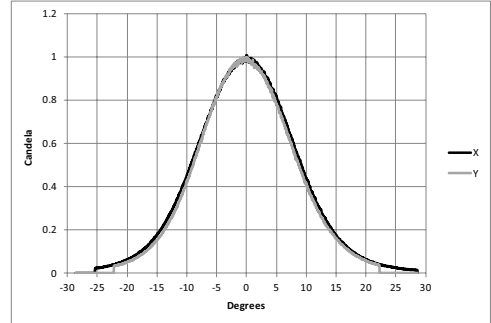

Iso-Illuminance Diagram (Flat Surface Distribution)

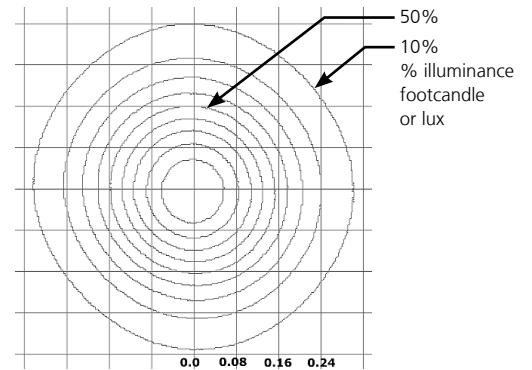

Candela Plot

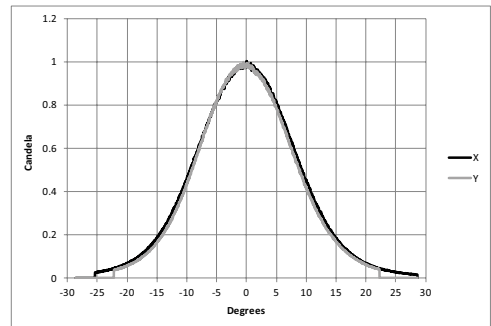

Iso-Illuminance Diagram (Flat Surface Distribution)

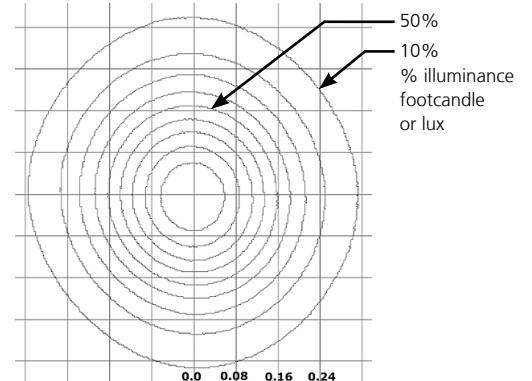

PHOTOMETRY INFORMATION

Source 4WRD Color PAR with NSP Lens

Model	Degree	Candela	Field Lumens	Beam Lumens	Power Consumption	Lumens Per Watt
3200 K	35.8	38,931	3,727	1,666	102.1 W	36.5
5600 K	35.8	47,062	4,505	2,014	129.0 W	34.9
Full on	35.8	52,390	5,015	2,242	144.0 W	34.8

Metric conversions: For meters, multiply feet by 0.3048.
For lux, multiply footcandles by 10.76.

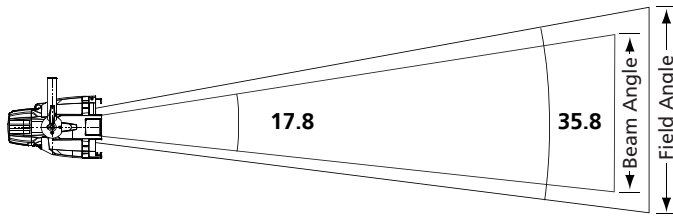

Throw Distance (d)	10 ft 3.0 m	15 ft 4.6 m	20 ft 6.1 m	25 ft 7.6 m	228.9 ft 69.8 m
Field Diameter	6.5 ft 2.0 m	9.7 ft 3.0 m	12.9 ft 3.9 m	16.1 ft 4.9 m	-
Illuminance (fc)	524	233	131	84	1
Illuminance (lux)	5,639	2,506	1,410	902	10.76

To determine center beam illumination in footcandles at any throw distance, divide candela by the throw distance squared.

For field diameter at any distance, multiply distance by 0.646.
For beam diameter at any distance, multiply by 0.313.

Source 4WRD Color PAR with MFL Lens

Model	Degree	Candela	Field Lumens	Beam Lumens	Power Consumption	Lumens Per Watt
3200 K	47.3	25,251	3,665	1,685	102.1 W	35.9
5600 K	47.3	30,524	4,430	2,036	129.0 W	34.3
Full on	47.3	33,980	4,932	2,267	144.0 W	34.3

Metric conversions: For meters, multiply feet by 0.3048.
For lux, multiply footcandles by 10.76.

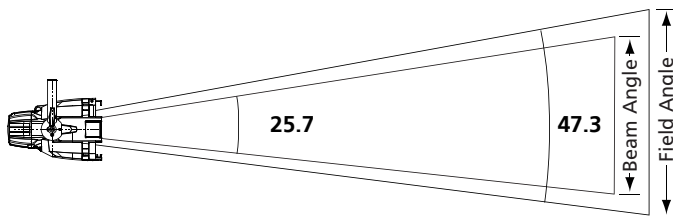

Throw Distance (d)	10 ft 3.0 m	15 ft 4.6 m	20 ft 6.1 m	25 ft 7.6 m	184.3 ft 56.2 m
Field Diameter	8.8 ft 2.7 m	13.1 ft 4.0 m	17.5 ft 5.3 m	21.9 ft 6.7 m	-
Illuminance (fc)	340	151	85	54	1
Illuminance (lux)	3,658	1,626	914	585	10.76

To determine center beam illumination in footcandles at any throw distance, divide candela by the throw distance squared.

For field diameter at any distance, multiply distance by 0.702.
For beam diameter at any distance, multiply by 0.329.

Candela Plot

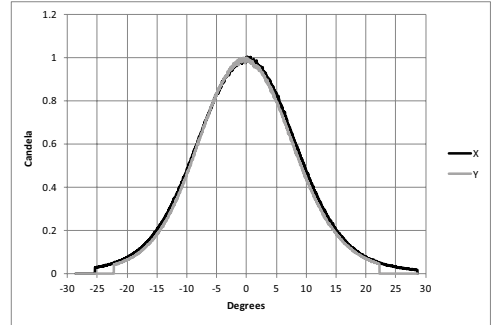

Iso-Illuminance Diagram (Flat Surface Distribution)

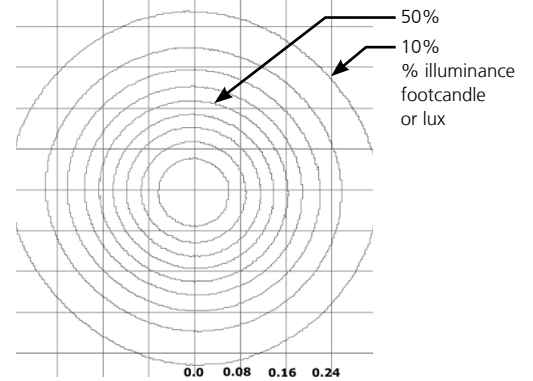

Candela Plot

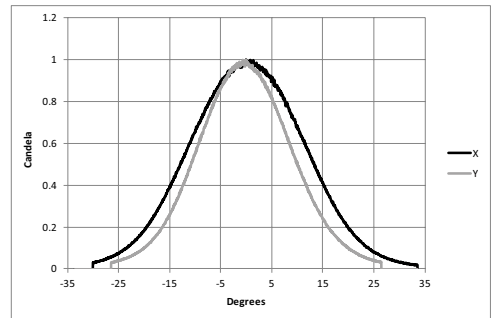

Iso-Illuminance Diagram (Flat Surface Distribution)

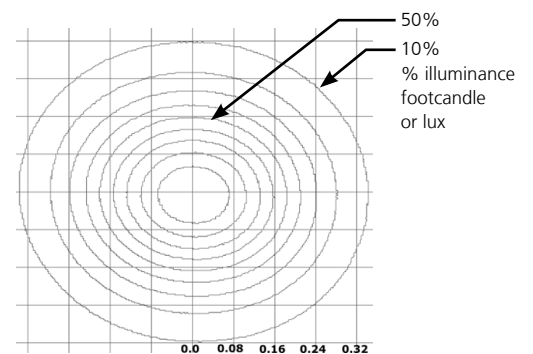

PHOTOMETRY INFORMATION

Source 4WRD Color PAR with WFL Lens

Model	Degree	Candela	Field Lumens	Beam Lumens	Power Consumption	Lumens Per Watt
3200 K	63.1	12,650	3,726	1,961	102.1 W	36.5
5600 K	63.1	15,292	4,504	2,371	129.0 W	34.9
Full on	63.1	17,023	5,014	2,639	144.0 W	34.8

Metric conversions: For meters, multiply feet by 0.3048.
For lux, multiply footcandles by 10.76.

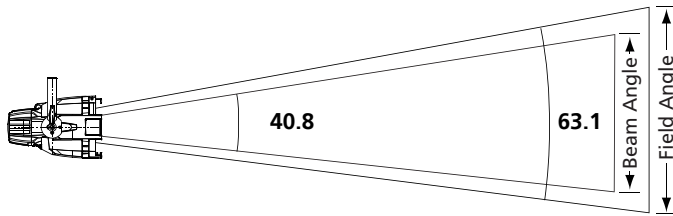

Throw Distance (d)	10 ft 3.0 m	15 ft 4.6 m	20 ft 6.1 m	25 ft 7.6 m	130.5 ft 39.8 m
Field Diameter	12.3 ft 3.7 m	18.4 ft 5.6 m	24.6 ft 7.5 m	30.7 ft 9.4 m	-
Illuminance (fc)	170	76	43	27	1
Illuminance (lux)	1,832	814	458	293	10.76

To determine center beam illumination in footcandles at any throw distance, divide candela by the throw distance squared.

For field diameter at any distance, multiply distance by 1.228.
For beam diameter at any distance, multiply by 0.744.

Candela Plot

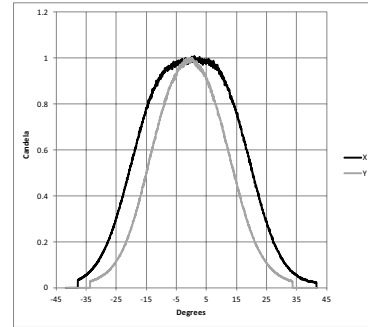

Iso-Illuminance Diagram (Flat Surface Distribution)

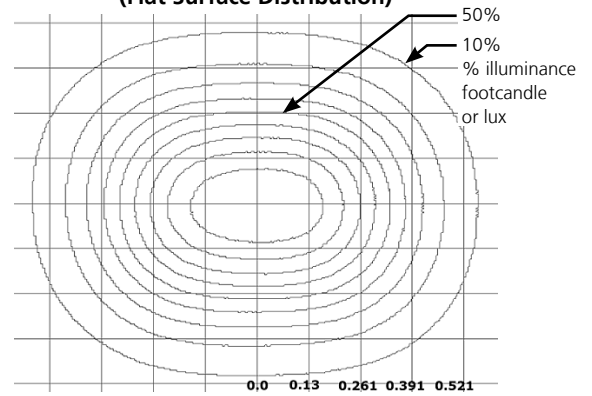

Source 4WRD Color PAR with XWFL Lens

Model	Degree	Candela	Field Lumens	Beam Lumens	Power Consumption	Lumens Per Watt
3200 K	68.0	7,557	2,423	947	102.1 W	23.7
5600 K	68.0	9,135	2,928	1,145	129.0 W	22.7
Full on	68.0	10,169	3,260	1,275	144.0 W	22.6

Metric conversions: For meters, multiply feet by 0.3048.
For lux, multiply footcandles by 10.76.

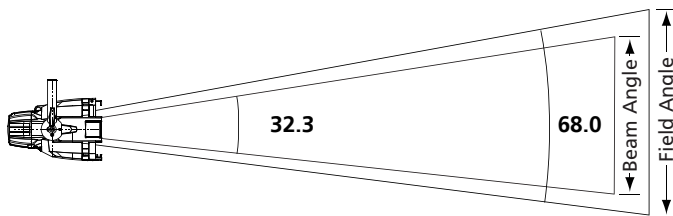

Throw Distance (d)	10 ft 3.0 m	15 ft 4.6 m	20 ft 6.1 m	25 ft 7.6 m	100.8 ft 30.7 m
Field Diameter	13.5 ft 4.1 m	20.2 ft 6.2 m	27.0 ft 8.2 m	33.7 ft 10.3 m	-
Illuminance (fc)	102	45	25	16	1
Illuminance (lux)	1,095	486	274	175	10.76

To determine center beam illumination in footcandles at any throw distance, divide candela by the throw distance squared.

For field diameter at any distance, multiply distance by 1.349.
For beam diameter at any distance, multiply by 0.578.

Candela Plot

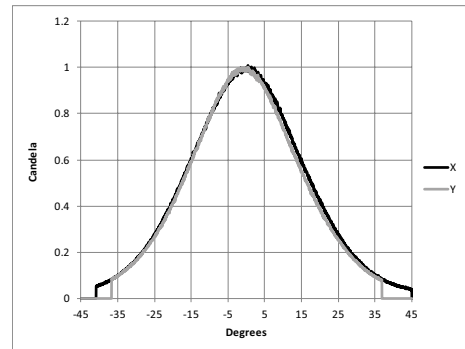

Iso-Illuminance Diagram (Flat Surface Distribution)

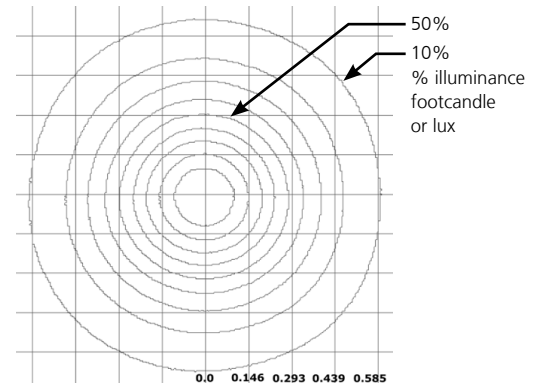

PHOTOMETRY INFORMATION

Source 4WRD Color PARNel Spot

Model	Degree	Candela	Field Lumens	Beam Lumens	Power Consumption	Lumens Per Watt
3200 K	33.7	42,372	3,502	1,478	102.1 W	34.3
5600 K	33.7	52,037	4,267	1,794	129.0 W	33.1
Full on	33.7	55,757	4,604	1,951	144.0 W	32.0

Metric conversions: For meters, multiply feet by 0.3048.
For lux, multiply footcandles by 10.76.

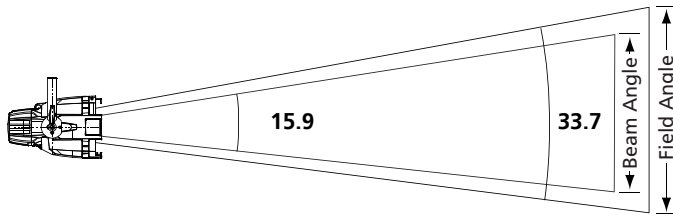

Throw Distance (d)	10 ft 3.0 m	15 ft 4.6 m	20 ft 6.1 m	25 ft 7.6 m	236.1 ft 72.0 m
Field Diameter	6.1 ft 1.8 m	9.1 ft 2.8 m	12.1 ft 3.7 m	15.1 ft 4.6 m	-
Illuminance (fc)	558	248	139	89	1
Illuminance (lux)	6,002	2,667	1500	960	10.76

To determine center beam illumination in footcandles at any throw distance, divide candela by the throw distance squared.

For field diameter at any distance, multiply distance by 0.605.
For beam diameter at any distance, multiply by 0.279.

Source 4WRD Color PARNel Flood

Model	Degree	Candela	Field Lumens	Beam Lumens	Power Consumption	Lumens Per Watt
3200 K	51.9	16,829	3,651	1,660	102.1 W	35.8
5600 K	51.9	20,295	4,432	2,033	129.0 W	34.4
Full on	51.9	21,260	4,624	2,109	144.0 W	32.1

Metric conversions: For meters, multiply feet by 0.3048.
For lux, multiply footcandles by 10.76.

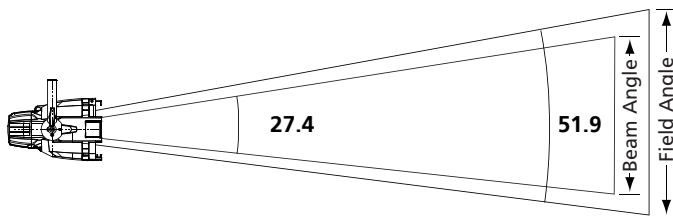

Throw Distance (d)	10 ft 3.0 m	15 ft 4.6 m	20 ft 6.1 m	25 ft 7.6 m	145.8 ft 44.4 m
Field Diameter	9.7 ft 3.0 m	14.6 ft 4.5 m	19.5 ft 5.9 m	24.3 ft 7.4 m	-
Illuminance (fc)	213	94	53	34	1
Illuminance (lux)	2,288	1,017	572	366	10.76

To determine center beam illumination in footcandles at any throw distance, divide candela by the throw distance squared.

For field diameter at any distance, multiply distance by 0.974.
For beam diameter at any distance, multiply by 0.487.

Candela Plot

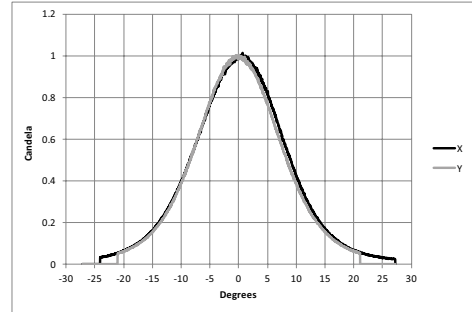

Iso-Illuminance Diagram (Flat Surface Distribution)

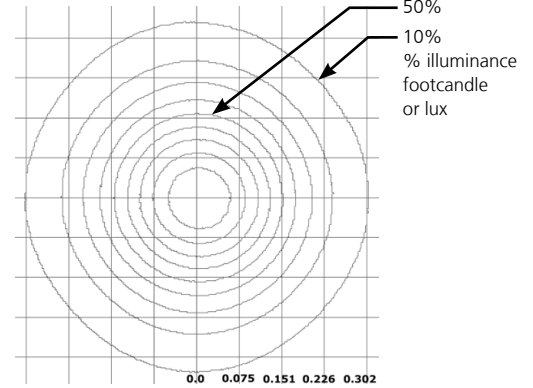

Candela Plot

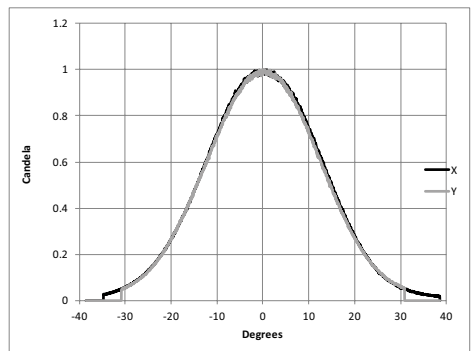

Iso-Illuminance Diagram (Flat Surface Distribution)

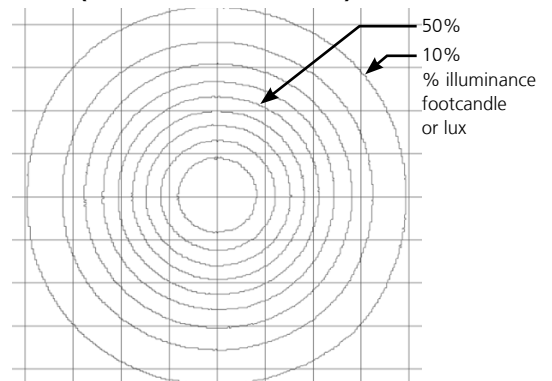

PHYSICAL

Source 4WRD PAR/PARNel Dimensions

MODEL	HEIGHT		WIDTH		DEPTH	
	in	mm	in	mm	in	mm
4WRD PAR	11.04	280	10.63	270	12.79	325
4WRD PARNel	11.68	296	10.63	270	12.79	325

Source 4WRD PAR/PARNel Weights

MODEL	WEIGHT*		SHIPPING WEIGHT		WEIGHT WITH S4WRD COLOR*	
	lb	kg	lb	kg	lb	kg
4WRD PAR	6.25	2.83	8.20	3.72	9.95	4.51
4WRD PARNel	7.70	3.49	9.65	4.34	11.40	5.17

*Without mounting hardware

SOURCE 4WRD PAR (WITH SOURCE 4WRD COLOR)

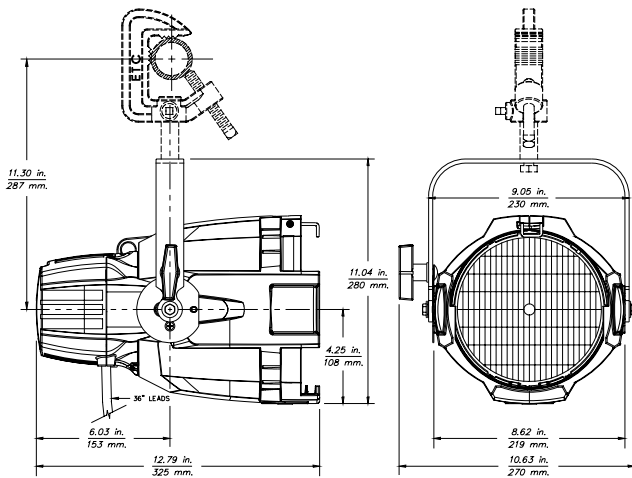

SOURCE 4WRD PARNEL (WITH SOURCE 4WRD COLOR)

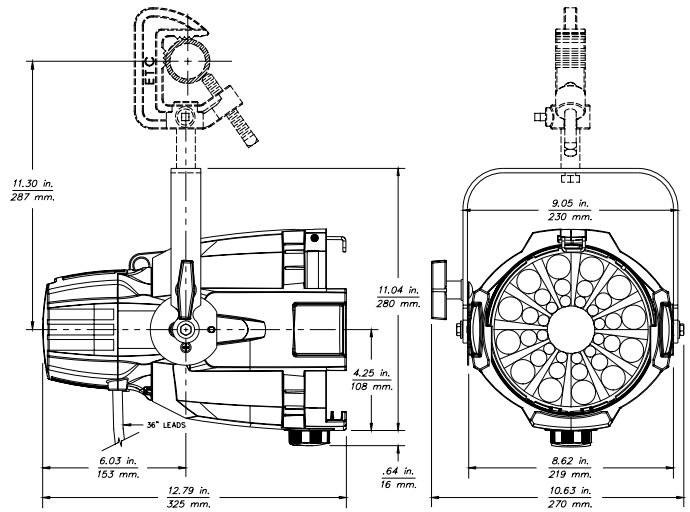

SOURCE 4WRD PAR (BODY ONLY)

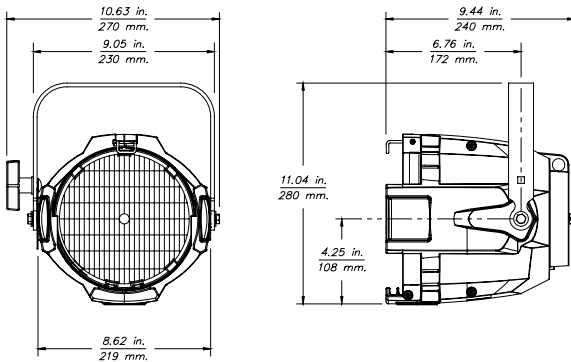

SOURCE 4WRD PARNEL (BODY ONLY)

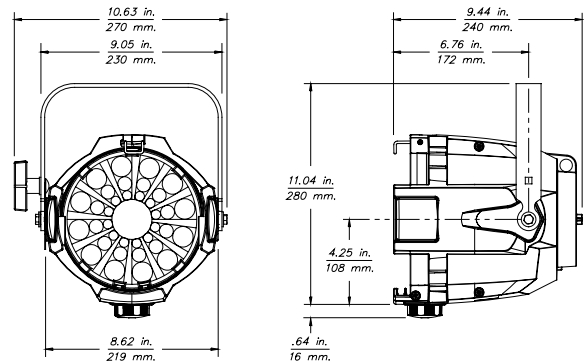

Corporate Headquarters • Middleton, WI USA
 Global Offices • London, UK • Rome, IT • Holzkirchen, DE • Paris, FR • Hong Kong
 Dubai, UAE • Singapore • New York, NY • Orlando, FL • Los Angeles, CA • Austin, TX
 Copyright©2021 ETC. All Rights Reserved. All product information and specifications subject to change. Rev C 2021-08
 *Trademark and patent info: etcconnect.com/IF