









Stands



Manfrotto's range of stands consists of several product families which differ in design and materials depending both on the applications they are intended for and on the light type they have to support. These supports can be distinguished by the materials they are made of (aluminum or steel) and two tubing technologies (electrowelding or extrusion). Special attention has been paid to multiple technical solutions like pneumatic damping and levelling legs. The existing versions allow for extensions between 21cm and 550cm, with payloads between 1.5kg and 200kg.



MODEL		PRODUCTS	CODE
BABY LIGHTWEIGHT		Backlite Stand	012B
		Nano Pole stand	MS0490A
		Black ALU LOW Mini Pro Stand	156BLB
		Black ALU NANO Stand	5001B
		Black ALU AIR Cushioned Mini Compact Stand	1051BAC
		Black ALU AIR Cushioned Compact Stand	1052BAC
		Black ALU AIR Cushioned Master Stand	1004BAC
		Black ALU AIR Cushioned Ranker Stand	1005BAC
JUNIOR STANDS		Black ALU Stand	008BU
		STEEL Junior Stand	008CSU
		Black ALU Senior Stand	007BU
		Black STEEL Senior Stand	007BSU
		STEEL Senior Stand	007CSU
		Black STEEL Tall Stand	111BSU
		STEEL Tall Stand	111CSU
		Black STEEL Heavy Duty Stand	126BSU
		STEEL Heavy Duty Stand	126CSU
		Black ALU Super Stand	269BU
		Black STEEL Super Stand	270BSU
		STEEL Super Stand	270CSU
		Black ALU High Super Stand	269HDBU
		Extensions Black ALU Stand	142B
		Extensions STEEL High Stand	146CS
Extensions STEEL Stand	142CS		
Extensions ALU High Stand	146B		
ROLLER		STEEL Column Stand	231CS
		Black ALU Column Stand	231B
		Black Baby Studio Stand	299B
		Black ALU studio Stand	298B
		BASE Black Large Brake	297BBASE
		Base Black Large Foot	297FBASE
		Base Black Small Brake	299BBASE
		Base Black Small Foot	299FBASE
WIND-UP		STEEL 3-section Low Base Wind Up Stand	087NWL B
		STEEL 2-section Low Base Wind Up Stand	083NWL B
		STEEL Wind Up Stand	087NW
		Black STEEL Wind Up Stand	087NWB
		STEEL Short Wind Up Stand	087NWSH
		STEEL 2-section Wind Up Stand	083NW
		STAINLESS STEEL Super Wind Up Stand	387XU
		Black STAINLESS STEEL Super Wind Up Stand	387XBU
LIGHTING BOOMS & BOOM STANDS		Black ALU Combi-Boom Stand with Sandbag	420B
		Combi-Boom Stand HD	420CSU
		Black Mega Boom (stand not included)	425B
		Black Light Boom 35 (stand not included)	085BSL
		Black Light Boom 35 (stand included)	085BS
		Black Super Boom (stand not included)	025BSL
		Black Super Boom (stand included)	025BS
		Black Light Boom (stand not included)	024B
		Super Boom with Column Stand	025TM
		Black Wall Boom (stand not included)	098B
		Black Short Wall Boom (stand not included)	098HB

PAYLOAD								HEIGHT & WEIGHT			ATTACHMENT
≤ 2 kg	≤ 5 kg	≤ 10 kg	≤ 15 kg	≤ 20 kg	≤ 25 kg	≤ 30 kg	≥ 30 kg	 cm	 cm	 kg	
√								85	48	1,32	Spigot 5/8" M, Bushing 5/8" F, 3/8" thread Male
√								195	49	1,07	
√								123	40	1,50	
√								190	48	0,93	
	√							211	67	1,00	
	√							237	86	1,20	
		√						366	107	3,00	
		√						237	100	2,00	Bushing 5/8" F / diameter 17mm M (JP), Spigot 5/8" M, 1/4" W thread Male, 3/8" thread Male
			√					212	112	4,20	Bushing 1 1/8" F, Spigot 5/8" M, 3/8" thread Male
						√		216	116	6,40	
			√					315	122	3,00	
				√				325	122	7,30	
				√				325	122	7,30	
					√			380	155	9,00	
					√			380	155	9,00	
							√	333	131	8,30	
							√	333	131	8,30	
							√	455	144	8,00	
							√	477	144	13,50	
							√	477	144	13,50	
		√						730	173	10,00	
							Extension	210		2,40	
							Extension	314		4,80	
							Extension	210		3,60	
							Extension	314		2,80	
		√						250	121	8,00	Spigot 5/8" M, Bushing 5/8" F, 1/4" W thread Male, 3/8" thread Male
		√						250	121	6,40	
			√					272	105	4,80	Bushing 5/8" F / diameter 17mm M (JP), Spigot 5/8" M, 1/4" W thread Male, 3/8" thread Male
			√					300	125	6,00	
							√		52	5,70	Bushing 1 1/8" F, Spigot 5/8" M, 3/8" thread Male
							√		52	4,40	
							√		36	4,80	
							√		36	3,50	
						√		276	134	16,00	Bushing 1 1/8" F, Spigot 5/8" M, 3/8" thread Male
							√	190	112	11,00	
						√		370	181	21,40	
						√		370	181	21,40	
						√		276	155	15,50	
							√	247	153	16,00	Bushing 1 1/8" F
							√	366	184	32,50	
							√	366	184	32,50	
		√						392	113	2,70	Bushing 5/8" F / diameter 17mm M (JP), Spigot 5/8" M, 1/4" W thread Male, 3/8" thread Male
			√					392	113	5,60	
6kg at max extension, 30kg at minimum extensions, both with 30kg of counterweight								320		15,00	Bushing 1 1/8" F, Bushing 5/8" F
6kg at max extension with 7kg of counterweight								280		2,20	Bushing 5/8" F / diameter 17mm M (JP), Spigot 5/8" M, 1/4" W thread Male, 3/8" thread Male
6kg at max extension with 7kg of counterweight								280		16,40	
5kg at max extension with 7kg of counterweight								270		4,10	Spigot 5/8" M, 3/8" thread Male
5kg at max extension with 7kg of counterweight								100		21,00	Spigot 5/8" M, 3/8" thread Male
3kg at max extension with 4,5kg of counterweight								200		1,40	Bushing 5/8" F / diameter 17mm M (JP), Spigot 5/8" M, 1/4" W thread Male, 3/8" thread Male
5kg at max extension with 7kg of counterweight								108		18,50	Spigot 5/8" M, 3/8" thread Male
4,5kg at max extension								210		2,30	Bushing 5/8" F / diameter 17mm M (JP), Spigot 5/8" M, 1/4" W thread Male, 3/8" thread Male
	√							122		2,00	Bushing 5/8" F / diameter 17mm M (JP), Spigot 5/8" M, 1/4" W thread Male, 3/8" thread Male

BABY LIGHTWEIGHT STANDS

This series of Manfrotto baby lighting stands are ideal for most photographic strobe heads and lighter weight fixtures and LED lights. They fold quickly to a compact size, fitting into most lighting kits. They are the versatile and lightweight companion for shoots in studio or on location.



A stronger and more ergonomic handle helps you while securing stands into the operating position.



Just a click away from your baby. Push on the new locking device and detach one stand, ready to go.



Anti-rotation 3/8" top screw fixing, plus 1/4" adapter for matching any requirement.

Excellent protection against corrosion and wear is ensured by aluminium anodization.

Versions featuring air cushioning for preventing damage to the lighting fixture during column retraction.











A new bi-injection casting provides the photographer with a better ergonomic grip.



BACKLITE STAND 012B

Black steel base with detachable aluminium column. 2 sections, 1 riser. Ø: 22, 19mm. Solid flat legs: 20x5mm. A versatile stand allowing fixtures to mount on the ground or on the included pole for extra height.

-  9cm
-  85cm
-  48cm
-  60cm
-  1.32kg
-  Pole type 18
+ type 19
-  3kg
-  Base type 1
+ Spigot Art. 013



BLACK ALU LOW MINI PRO STAND 156BLB

Aluminium stand. 4 sections, 3 risers. Ø: 25, 22, 19, 16mm. Leg Ø: 16mm. Perfect for background lights.

-  40cm
-  123cm
-  40cm
-  45cm
-  0.62kg
-  1.5kg
-  Type 19
+ Adapter Art. 015



BLACK ALU NANO STAND 5001B

Aluminium stand. 5 sections, 4 risers. Ø: 25, 22, 19, 16, 13mm. Solid flat legs 15x5mm. An ideal stand for kits due to its compact design.

-  49cm
-  190cm
-  48cm
-  100cm
-  0.93kg
-  1.5kg
-  Type 19
+ Adapter Art. 015



NANO POLE STAND MS0490A

Aluminium stand, compact stand with 5 sections, 4 risers. The column can be detached from the base and used as a boom.

-  49cm
-  195cm
-  49cm
-  100cm
-  1.07kg
-  1.5kg
-  Type 19

ADAPTO

Material alternatives are crucial to provide high performance and light weight.

Adapto® is the new material specifically developed by Manfrotto for both collars and spider castings of the 1051BAC MINI COMPACT STAND and the 1052BAC COMPACT STAND.









Adapto® is a special technical polymer that is comparable to aluminium in strength, but is 50% lighter. Adapto® is an ideal material for photo imaging equipment as it has superb resistance to extreme temperatures and will not corrode or oxidize. Additionally, Adapto® is an excellent vibration absorption material, making our equipment the ultimate in vibration free shots.

New Adapto® collars are made from a single locking component, ensuring better performance and easier maintenance.



**BLACK ALU AIR CUSHIONED
MINI COMPACT STAND 1051BAC**

Aluminium stand, air cushioned. 4 sections, 3 risers.
Ø: 25, 22, 19, 16mm. Leg Ø: 19mm.

-  75cm
-  211cm
-  67cm
-  70cm
-  1kg
-  4kg
-  Type 19
+ Adapter Art. 015
-  017











**BLACK ALU AIR CUSHIONED MINI
COMPACT STAND IN 3-PACK 1051BAC-3**

Same as 1051BAC, available in 3-pack. Not illustrated



**BLACK ALU AIR CUSHIONED
COMPACT STAND 1052BAC**

Aluminium stand, air cushioned. 3 sections, 2 risers.
Ø: 25, 22, 19mm. Leg Ø: 19mm.

-  101cm
-  237cm
-  86cm
-  109cm
-  1.2kg
-  5kg
-  Type 19
+ Adapter Art. 015
-  017



**BLACK ALU AIR CUSHIONED
COMPACT STAND IN 3-PACK 1052BAC-3**

Same as 1052BAC, available in 3-pack. Not illustrated



With the piling system portability is at the essence! Cling them together and save a lot of room in the studio or carry them in a compact case to easily bring them with you for outdoor shooting. The new baby is now able to stand up on its own even when it's closed.



BLACK ALU AIR CUSHIONED MASTER STAND 1004BAC

Aluminium stand, air cushioned. 4 sections, 3 risers.
 Ø: 35, 30, 25, 20mm. Leg Ø: 22mm.

- -
 -
 -
 -
 -
 -
 -
- + Adapter Art. 015



BLACK ALU AIR CUSHIONED MINI MASTER STAND IN 3-PACK 1004BAC-3

Same as 1004BAC, available in 3-pack. Not illustrated



MINI BACKLITE BASE FEMALE ATTACHMENT 003MF

The hole at the end of each leg enables the user to nail the stand to the floor, hang it on a wall or fix it to the ceiling.

-
-
-
-
-



BLACK ALU AIR CUSHIONED RANKER STAND 1005BAC

Aluminium stand, air cushioned. 3 sections, 2 risers.
 Ø: 35, 30, 25mm. Leg Ø: 22mm.

- -
 -
 -
 -
 -
 -
 -
- + Spigot Art. 013



BLACK ALU AIR CUSHIONED MINI RANKER STAND IN 3-PACK 1005BAC-3

Same as 1005BAC, available in 3-pack. Not illustrated



MINI BACKLITE BASE MALE ATTACHMENT 003M

Same as 003MF but with 16mm male attachment (Type 22).

-
-
-
-
-



BACKLITE BASE 003

Fold away base.

- -
 -
 -
 -
- + Spigot Art.013

JUNIOR STANDS

Junior Lighting stands are medium-high payload stands, suitable for supporting reflectors or luminaires in studio or location. Chrome steel, black zinc and silver or black aluminum versions are available, all with double braced leg base for extra stability and safety. Optional air cushioning as indicated in the product code description (AC).



28mm die cast aluminium socket together with a 16mm stud.



All versions feature levelling leg for better stability.



Double braced legs for better stability, resistance and safety.











All stands in the series can be equipped with wheels either braked wheels.



BLACK ALU STAND 008BU









Black aluminium stand. 2 sections, 1 riser.
 Ø: 35, 30mm. Leg Ø: 22mm. 1 levelling leg.

- 
 131cm
- 
 212cm
- 
 112cm
- 
 118cm
- 
 4.2kg
- 
 15kg
- 
 3kg@212cm
- 
 Type 14
- 
 109, 110, 110G



STEEL JUNIOR STAND 008CSU











Chrome plated steel stand. 2 sections, 1 riser.
 Ø: 35, 30mm. Leg Ø: 22mm. 1 levelling leg.

- 
 132cm
- 
 216cm
- 
 116cm
- 
 118cm
- 
 6.4kg
- 
 30kg
- 
 18kg@216cm
- 
 Type 14
- 
 110, 110G



BLACK ALU SENIOR STAND 007BU AC











Aluminium stand. 3 sections, 2 risers.
 Ø: 35, 30, 25mm. Leg Ø: 22mm. 1 levelling leg.

				
124cm	315cm	122cm	118cm	3kg
				
12kg	2.5kg@315cm	Type 14	109, 110, 110G	



BLACK STEEL SENIOR STAND 007BSU









Black chrome plated steel stand. 3 sections, 2 risers.
 Ø: 35, 30, 25mm. Leg Ø: 22mm. 1 levelling leg.

				
124cm	325cm	122cm	118cm	7.3kg
				
20kg	6.7kg@325cm	Type 14	109, 110, 110G	



STEEL SENIOR STAND **007CSU**









Chrome plated steel stand. 3 sections, 2 risers.
 Ø: 35, 30, 25mm. Leg Ø: 22mm. 1 levelling leg.

				
124cm	325cm	122cm	118cm	7.3kg
				
20kg	6.7kg@325cm	Type 14	109, 110, 110G	



BLACK STEEL TALL STAND **111BSU**









Black chrome plated steel stand. 3 sections, 2 risers.
 Ø: 35, 30, 25mm. Leg Ø: 22mm. 1 levelling leg.
 The small footprint makes this stand perfect for tight spaces.

				
146cm	380cm	155cm	102cm	9kg
				
25kg	6kg@380cm	Type 14	103, 104, 104G	



STEEL TALL STAND 111CSU









Chrome plated steel stand. 3 sections, 2 risers.
 Ø: 35, 30, 25mm. Leg Ø: 22mm. 1 levelling leg.
 The small footprint makes this stand perfect for tight spaces.

-  146cm
-  380cm
-  155cm
-  102cm
-  9kg
-  25kg
-  6kg@380cm
-  Type 14
-  103, 104, 104G



BLACK STEEL HEAVY DUTY STAND 126BSU AC









Chrome plated steel stand. 3 sections, 2 risers.
 Ø: 40, 35, 30mm. Leg Ø: 22mm. 1 levelling leg.

-  131cm
-  333cm
-  131cm
-  126cm
-  8.3kg
-  40kg
-  3kg@333cm
-  Type 14
-  109, 110, 110G



STEEL HEAVY DUTY STAND 126CSU AC









Chrome plated steel stand. 3 sections, 2 risers.
 Ø: 40, 35, 30mm. Leg Ø: 22mm. 1 levelling leg.

- 
 131cm
- 
 333cm
- 
 131cm
- 
 126cm
- 
 8.3kg
- 
 40kg
- 
 3kg@333cm
- 
 Type 14
- 
 109, 110, 110G



BLACK ALU SUPER STAND 269BU

Aluminium stand. 4 sections, 3 risers.
 Ø: 50, 45, 40, 35mm. Leg Ø: 30mm. 1 levelling leg.

- 
 144cm
- 
 455cm
- 
 144cm
- 
 174cm
- 
 8kg
- 
 35kg
- 
 6.3kg@455cm
- 
 Type 14
- 
 103, 104, 104G



BLACK STEEL SUPER STAND **270BSU**

Black chrome plated steel stand. 4 sections, 3 risers. Ø: 50, 45, 40, 35mm. Leg Ø: 30mm. 1 levelling leg.
 There is a reason we call this the super stand! Incredible reach of 477cm that can support fixtures up to 40kg.



144cm



477cm



144cm



174cm



13.5kg



40kg



12kg@477cm



Type 14



103, 104, 104G



STEEL SUPER STAND **270CSU**

Chrome plated steel stand. 4 sections, 3 risers.
Ø: 50, 45, 40, 35mm. Leg Ø: 30mm. 1 levelling leg.



144cm



477cm



144cm



174cm



13.5kg



40kg



12kg@477cm



Type 14



103, 104, 104G



BLACK ALU HIGH SUPER STAND 269HDBU

Aluminium stand. 6 sections, 5 risers.
Ø: 50, 45, 40, 35, 30, 25mm. Leg Ø: 30mm. 1 levelling leg.



190cm



730cm



173cm



174cm



10kg



10kg



1kg@730cm



Type 14



103, 104, 104G



BLACK ALU STAND EXTENSION 142B

2 section (Ø 35, 30mm) black aluminium extension.
Minimum height: 125cm. Maximum height: 210cm.



2.4kg



Top type 14



Bottom type 37



STEEL HIGH STAND EXTENSION 146CS

3 section (Ø 35, 30, 25mm) chrome steel extension.
Minimum height: 137cm. Maximum height: 314cm.



4.8kg



Top type 14



Bottom type 37



STEEL STAND EXTENSION 142CS

2 section (Ø 35, 30mm) chrome steel extension.
Minimum height: 125cm. Maximum height: 210cm.



3.6kg



Top type 14



Bottom type 37



BLACK ALU HIGH STAND EXTENSION 146B

3 section (Ø 35, 30, 25mm) black aluminium extension.
Minimum height: 137cm. Maximum height: 314cm.



2.8kg



Top type 14



Bottom type 37

ROLLER STANDS

Roller stands are characterized by low profile bases that slip easily into position on set. All models are supplied with free running wheels and positive brakes.



Quick action folding legs.

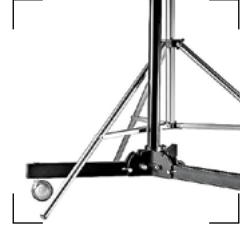

Low profile or an easier and quicker positioning of light fixtures.











Levelling leg.





STEEL COLUMN STAND 231CS









Chrome plated steel post: Ø: 35mm.
 Height of light fixture: from ground level to 250cm.
 Complete with braked wheels. 1 levelling leg.

- 
 35cm
- 
 250cm
- 
 121cm
- 
 100cm
- 
 8kg
- 
 8kg
- 
 5kg@250cm
- 
 Type 1
 + Spigot Art. 013



BLACK ALU COLUMN STAND 231B

Black aluminium post: Ø: 35mm.
 Height of light fixture: from ground level to 250cm.
 Complete with braked wheels. 1 levelling leg.

- 
 35cm
- 
 250cm
- 
 121cm
- 
 100cm
- 
 6.4kg
- 
 8kg
- 
 2kg@250cm
- 
 Type 1
 + Spigot Art. 013



BLACK BABY STUDIO STAND **299B**

Black steel base, silver anodised aluminium sections, complete with wheels. 3 sections, 2 risers. Ø: 35, 30, 25mm. 1 levelling leg.

108cm	272cm	105cm	75cm	4.8kg
12kg	2.2kg@272cm	Type 3 + Spigot Art. 013		



BLACK ALU STUDIO STAND **298B**







Black steel base, silver anodised aluminium sections, complete with wheels. 3 sections, 2 risers. Ø: 35, 30, 25mm. 1 levelling leg.

129cm	300cm	125cm	100cm	6kg
15kg	5kg@300cm	Type 14		



BLACK LARGE BRAKE BASE 297BBASE







1 levelling leg.
Complete with braked wheels.

-  28cm
-  52cm
-  100cm
-  5.7kg
-  40kg
-  Type 14



BLACK LARGE FOOT BASE 297FBASE







1 levelling leg.
Complete with feet.

-  21cm
-  52cm
-  100cm
-  4.4kg
-  40kg
-  Type 14



BLACK SMALL BRAKE BASE 299BBASE







1 levelling leg.
Complete with braked wheels.

-  28cm
-  36cm
-  75cm
-  4.8kg
-  40kg
-  Type 14



BLACK SMALL FOOT BASE 299FBASE

1 levelling leg.
Complete with feet.

-  21cm
-  36cm
-  75cm
-  3.5kg
-  40kg
-  Type 14

WIND UP STANDS

Mighty stands that reach high height. Made by chrome or stainless steel, single and double risers which extend simultaneously. Levelling leg for easy positioning and double braces leg base for extra stability and safety.



Cable transmission is fully inside sections.

Third internal safety cable.

"Safe finger" protection.



Bolts: all wind up stands assembled using bolts instead of rivets for easier maintenance.



Fold away crank handle for avoiding split up during usage and reducing protrusion during storage.



Double braced legs for better stability, resistance and safety.



All versions feature levelling leg for better stability.

Footrest for easy access to top section.



All stands in the series can be equipped with wheels either braked wheels.











Aluminium feet for improved stability and longer durability.



STEEL 3 SECTION LOW BASE
WIND UP STAND **087NWL**









Geared centrepost steel stand. 3 sections, 2 risers.
Ø: 55, 45, 38mm. 1 levelling leg. Fitted with braked wheels.

- | | | | | |
|---|---|---|---|---|
|  |  |  |  |  |
| 144cm | 276cm | 134cm | 100cm | 16kg |
|  |  |  | | |
| 30kg | 5.5kg@276cm | Type 14 | | |



STEEL 2 SECTION LOW BASE
WIND UP STAND **083NWL**

Geared centrepost steel stand. 2 sections, 1 riser.
Ø: 55, 45mm. 1 levelling leg. Fitted with braked wheels.

- | | | | | |
|---|---|---|---|---|
|  |  |  |  |  |
| 129cm | 190cm | 112cm | 100cm | 11kg |
|  |  |  | | |
| 35kg | 2.5kg@190cm | Type 14 | | |



STEEL WIND UP STAND **087NW**

Chrome steel stand with geared column.
 2 risers extend simultaneously at an elevation of 4.4cm per handle turn.
 Safety cable ensures simultaneous retrieval of all sections.
 3 sections, 2 risers. Ø: 55, 45, 38mm. Leg Ø: 30mm. 1 levelling leg.



167cm



370cm



181cm



128cm



21.4kg



30kg



30kg@370cm



Type 14 104, 104G, 374-10



BLACK STEEL WIND UP STAND **087NWB**

Black chrome steel stand with geared column.
 2 risers extend simultaneously at an elevation of 4.4cm per handle turn.
 Safety cable ensures simultaneous retrieval of all sections.
 3 sections, 2 risers. Ø: 55, 45, 38mm. Leg Ø: 30mm. 1 levelling leg.



167cm



370cm



181cm



128cm



21.4kg



30kg



30kg@370cm



Type 14 104, 104G, 374-10





STEEL SHORT WIND UP STAND 087NWSH

Short version of 087NW. 3 sections, 2 risers.
 Ø: 55, 45, 38mm. Leg Ø: 30mm. 1 levelling leg.

135cm	276cm	155cm	128cm	15.5kg
30kg	15kg@276cm	Type 14	104, 104G, 374-10	



STEEL 2 SECTION WIND UP STAND 083NW

Chrome steel stand with geared column. Elevation: 2.2cm per handle turn.
 2 sections, 1 riser. Ø: 55, 45mm. Leg Ø: 30mm. 1 levelling leg.

139cm	247cm	153cm	128cm	16kg
45kg	30kg@247cm	Type 14	104, 104G, 374-10	



STAINLESS STEEL SUPER WIND UP STAND 387XU

Heavy lift stand with strengthened stainless steel column and legs, chrome steel risers and geared column.
 3 sections Ø: 70, 60, 50mm.
 2 risers which extended simultaneously at 4.4cm per handle turn.
 Safety cable ensures simultaneous retrieval of all sections.
 Rapid adjustment. Leg Ø 35mm. 1 levelling leg.
 PATENTED



156cm



366cm



179cm



180cm



32.5kg



80kg



80kg@366cm



28mm



374





BLACK STAINLESS STEEL SUPER WIND UP STAND **387XBU**

Heavy lift stand with strengthened stainless steel column and legs, black chrome steel risers and geared column.
 3 sections Ø: 70, 60, 50mm.
 2 risers which extended simultaneously at 4.4cm per handle turn.
 Safety cable ensures simultaneous retrieval of all sections.
 Rapid adjustment. Leg Ø 35mm. 1 levelling leg.
 PATENTED



156cm



366cm



179cm



180cm



32.5kg



80kg



80kg@366cm



28mm



374



All Manfrotto stands provide for a high level of customisation, thanks to a wide range of accessories like wheels, sand bags, clips, wind-bracing kit and stans holder that can accept any lighting fixture, in order to match any requirement.

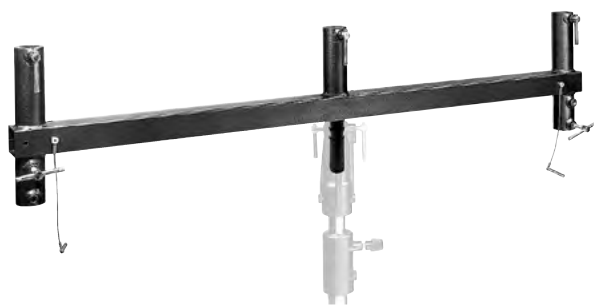

FIVE SOCKET BRACKET 169

100cm long T Bar with 5 x 28mm sockets for attaching up to 5 lighting fixtures. Designed to fit on stand or bracket with 28mm socket.
*When load on one side only, max load capacity: 15kg.

-  6.10kg
-  28mm
-  28mm
-  50kg*



THREE BABY BRACKET 154B

65cm long T Bar with 3 x 16mm sockets plus 3 x 16mm Spigot Art. 013. Designed to fit on stand or bracket with 16mm pin.

-  0.79kg
-  28mm
-  16mm + Spigot Art. 013



T BAR 614

4 x Lantern T Bar 1220mm long.



EXPAN ATTACHMENT 081

Another quick solution to hang your expan up to a baby stand.

-  0,204kg
-  Type 1



T BAR 613PAR

"T" Bar specifically design to carry six PAR 57 or 64 luminaires. Supplied with a built in TV male spigot. Max load capacity: 6kg on each attachments, only at the ends 12kg on each side.



WIND-BRACING KIT 087WBK

Wind-bracing kit of 3 ropes. Length: 10m. Not supplied with the stand.



STAND HOLDER 027

Holder for 8 light stands. Width: 115cm.
Distance between fixing holes: 64.4cm. Depth: 19cm.



2.8kg



SMALL SAND BAG G100-2

(Sand not supplied)



6kg



EXTRA LARGE SAND BAG G300

(Sand not supplied)



35kg

LARGE SAND BAG G200-1

(Sand not supplied)



10kg



SMALL CABLE CLIP 064

Clamps on Ø: 18mm to 26mm. Allen key not supplied.
Set of four.



0.02kg



LARGE CABLE CLIP 093

Clamps on Ø: 28mm to 40mm. Allen key not supplied.
Set of four.



0.03kg



CASTER WHEEL SET 017

Caster wheel set for stands with legs Ø: 19mm. Set of three.



0.45kg



10kg



CASTER WHEEL SET 018

Caster wheel set for stands with legs Ø: 22mm. Set of three.



0.45kg



10kg



WHEEL SET 104

Ø: 75mm with brakes and M10 attachment. Set of three.



1.5kg



75kg



WHEEL SET 109

Ø: 80mm without brakes and adapter for legs Ø: 22mm. Set of three.



1.43kg



60kg



WHEEL SET 110

Ø: 75mm with brakes and adapter for legs Ø: 22mm. Set of three.



1.7kg



75kg



WHEEL SET 104G

Ø: 100mm with brakes and M10 attachment. Set of three.



3kg



100kg



WHEEL SET 110G

Ø: 100mm with brakes and adapter for legs Ø: 22mm. Set of three.



3.2kg



100kg



WHEELS FOR SUPER WIND UP 374

Ø: 160mm with brakes. Set of three.



7.2kg



300kg

WHEELS FOR SUPER WIND UP 374-10

Not illustrated

Ø: 160mm with brakes and M10 attachment. Set of three.



7.2kg



300kg

Lighting booms and boom stands provide the idea unobtrusive way to position lighting and reflector equipment directly above the subject. Boom stands are the perfect answer to those who need the flexibility of a boom and a lighting stand in one unit. Available in lightweight aluminum and steel for any type of shoot. Using a special articulated joint, which work both as a locking collar and as a pivoting boom clamp, all Manfrotto upright boom stands can rapidly be converted into stands with horizontal boom arms.



Sandbag counterweight available.



5/8" top fixing with 3/8" screw fixing (adjustable 90°) and 1/4" adapter for matching any requirement.



A special articulated coupler allows this model to be used either as a normal stand or boom.



BLACK ALU COMBI-BOOM STAND WITH SANDBAG 420B

Aluminium stand. Supplied with sandbag counterweight (empty) for maximum stability and smoothness.
 4 sections, 3 risers. Ø: 35, 30, 25, 20mm. Leg Ø: 22mm.
 Minimum extension boom: 19cm
 Maximum extension boom: 191cm
 Maximum load at boom full extension: 2kg with counterweight.

- 131cm
- 392cm
- 113cm
- 109cm
- 2.7kg
- 9kg
- 0.9kg@392cm
- 018
- Type 25 + Spigot Art. 013



COMBI-BOOM STAND HD 420CSU

Same as 420B but with legs and column in steel, last two sections in aluminium.
 Maximum load at boom full extension: 5kg with 35kg of counterweight.

- 131cm
- 392cm
- 113cm
- 109cm
- 5.6kg
- 12kg
- 1.5kg@392cm
- 018
- Type 25 + Spigot Art. 013



BLACK LIGHT BOOM 35 (STAND NOT INCLUDED) 085BSL

Ø 35mm. 3 section boom arm complete with Pivoting Clamp 123, counterweight G-Peso 022, cable clips and locking key.
 Weight: 2.2kg, boom only.
 Dismantled length: 100cm.
 Assembled length: 280cm.
 Minimum extension from stand attachment: 10cm.
 Maximum extension from stand attachment: 250cm.
 Load: 6kg at maximum extension with 7kg of counterweight.



2.2kg



6kg



Type 25 + Spigot Art. 013



28mm stand attachment



BLACK SUPER BOOM (STAND NOT INCLUDED) 025BSL

Ø 35mm. 1 section boom complete with Pivoting Clamp 123, counterweight G-Peso 022, cable clips.
 Weight: 4.1kg, boom only.
 Remote control of lighting movement: 270cm long.
 Minimum extension from stand attachment: 24cm.
 Maximum extension from stand attachment: 100cm.
 Load: 5kg at maximum extension with 7kg of counterweight.



4.1kg



5kg



Type 17 + Rapidapt Art. 014-38



28mm stand attachment



BLACK MEGA BOOM (STAND NOT INCLUDED) 425B

Largest boom in the range, remote control of pan, tilt and rotation of lamina plus geared telescopic extension. Combination of black zinc steel and black anodised aluminium tubes. Supplied with carrying bags.

2 sections (Ø: 45, 55mm).

Folded length: 220cm.

Minimum extension from stand attachment: 50cm.

Maximum extension from stand attachment: 320cm.

* Load: 6kg at maximum extension with 30kg of counterweight.

30kg at minimum extension with 30kg of counterweight.

Suggested stands: Wind Up series.



15kg



6kg-30kg*



16mm/28mm



28mm stand attachment



Product in use



BLACK LIGHT BOOM 35 (STAND INCLUDED) 085BS

Not illustrated

Ø 35mm 3 sections boom arm complete with Pivoting Clamp 123, counterweight G-Peso 022, Cine Stand with casters, cable clips and locking key.

Weight: 2.2kg, boom only.

Dismantled length: 100cm.

Assembled length: 280cm.

Minimum extension from stand attachment: 10cm.

Maximum extension from stand attachment: 250cm.

Load: 6kg at maximum extension with 7kg of counterweight.



16.4kg



6kg



Type 25 + Spigot Art.013



28mm stand attachment



Product in use



BLACK SUPER BOOM (STAND INCLUDED) 025BS Not illustrated

Ø 35mm 1 section boom arm complete with Pivoting Clamp 123, counterweight G-Peso 022, Cable Clips and Cine Stand 008 with casters.

Weight: 4.1kg, boom only.

Remote control of lighting movement: 270cm long.

Minimum extension from stand attachment: 24cm.

Maximum extension from stand attachment: 100cm.

Load: 5kg at maximum extension with 7kg of counterweight.



21kg



5kg



Type 25 + Rapidapter Art. 014-38



28mm stand attachment



Product in use



BLACK LIGHT BOOM (STAND NOT INCLUDED) 024B

Boom attaches to the shaft of most lightstands with diameters of 19, 20, 25, 28mm.
 Ø: 25mm 3 section boom arm complete with Pivoting Clamp 124, counterweight G-Peso 023, cable clips and locking key.
 Weight: 1.4kg, boom only.
 Dismantled length: 71cm.
 Assembled length: 200cm.
 Minimum extension from stand attachment: 120cm.
 Maximum extension from stand attachment: 210cm.
 Load: 3kg at maximum extension with 4.5kg of counterweight.



1.4kg



3kg



Type 25 + Spigot Art. 013



SUPER BOOM WITH COLUMN STAND 025TM

Ø 35mm. 1 section boom arm complete with Pivoting Clamp 123, counterweight G-Peso 022, Cable Clips and Column Stand with casters.
 Weight: 4.1kg, boom only.
 Remote control of lighting movement: 140cm long.
 Minimum extension from stand attachment: 10cm.
 Maximum extension from stand attachment: 108cm.
 Load: 5kg at maximum extension with 7kg of counterweight.



18.5kg



5kg



Type 17+ Rapidapter Art. 014-38



28mm stand attachment



BLACK WALL BOOM (STAND NOT INCLUDED) 098B

Wall mounted boom arm. 2 sections (Ø 35, 29mm).
 Rotation: 160° vertically and 180° horizontally.
 Minimum extension from stand attachment: 120cm.
 Maximum extension from stand attachment: 210cm.
 Load: 4.5kg at maximum extension.



2.3kg



4.5kg



Type 15 + Spigot Art. 013



Product in use

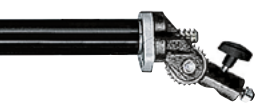

Product in use



**BLACK SHORT WALL BOOM
(STAND NOT INCLUDED) 098SHB**

Not illustrated

Minimum extension from stand attachment: 78cm.
Maximum extension from stand attachment: 12cm.

-  2kg
-  5kg
-  Type 25 + Spigot Art. 013



BLACK MINI BOOM 173B

Boom shaft Ø: 20mm. Length: 109cm.



0.32kg Type 18 and Type 19



PIVOTING BOOM CLAMP 123

Pivoting clamp for Ø 35mm boom shaft Ø 28mm male and Ø 16mm attachment.



0.72kg



PIVOTING BOOM CLAMP 124

Pivoting clamp for Ø: 19, 20, 25 and 28mm boom shafts (or any tubes of these diameters).



0.67kg



G-PESO 022

Counterweight. Clamps on Ø 22mm to 35mm.



6.7kg



MINI COUNTERWEIGHT 172

Clamps on bars from Ø 13mm to 30mm.



1,3kg

L-PESO 023

Not illustrated



4.3kg



EXTRA LARGE SAND BAG G300

(Sand not supplied)



35kg