

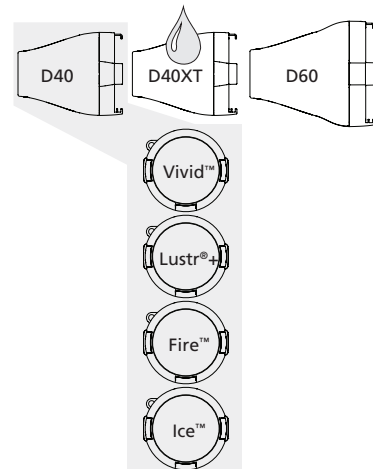

100/240V

**Selador Desire™ Series**

This datasheet covers D40 fixtures as shown.
See other datasheets for other versions.

GENERAL INFORMATION

ETC's Desire Series D40 luminaire family transforms our reknown Selador Classic Line into a round theatrical wash light. Highly efficient primary lenses and careful colour choices make the D40 fixture ideal for stage, studio and anywhere strong colour and high intensity is a requirement. The Selador x7 Color System™ produces the widest range of spectrally balanced saturated and tinted colour choices available. The D40's rugged die cast enclosure, noiseless fan-free operation, multiple lens options and advanced user interface make it ideal for multiple applications.

D40 LED ARRAY OPTIONS

D40 fixtures are based on the x7 Color System that uses seven different LED colours to achieve true, usable broad-spectrum colour. Equip a D40 luminaire with any one of the following x7 color arrays to best suit the intended application.

- *D40 Vivid* – the x7 Color System array balanced for best all-round use as a colour changing wash luminaire.
- *D40 Lustr+* – optimized with a high intensity white LED to create an ideal front lighting wash luminaire. Full range colour, with an emphasis on lighter colours and high quality white.
- *D40 Ice* – uses the cool colors of the x7 System to provide extra-high brightness colour in the blue area of the spectrum.
- *D40 Fire* - uses the warm colours of the x7 System to provide extra-high brightness colour in the red area of the spectrum.

ORDERING INFORMATION**Desire D40**

PART NO.	DESCRIPTION
7410A1401-0X	D40 Vivid wash luminaire, Black
7410A1401-1X	D40 Vivid wash luminaire, White
7410A1401-5X	D40 Vivid wash luminaire, Silver Grey
7410A1405-0X	D40 Lustr+ wash luminaire, Black
7410A1405-1X	D40 Lustr+ wash luminaire, White
7410A1405-5X	D40 Lustr+ wash luminaire, Silver Grey
7410A1404-0X	D40 Ice wash luminaire, Black
7410A1404-1X	D40 Ice wash luminaire, White
7410A1404-5X	D40 Ice wash luminaire, Silver Grey
7410A1403-0X	D40 Fire wash luminaire, Black
7410A1403-1X	D40 Fire wash luminaire, White
7410A1403-5X	D40 Fire wash luminaire, Silver Grey

Note: D40 luminaires ship with hanging yoke, 25° secondary lens and 1.5m PowerCon to bare ends power input lead.



Selador Desire™ Series

SPECIFICATIONS

GENERAL

- 40 LED colour mixing wash fixture
- Rated for IP20 dry location use
- CE compliant, UL and cUL Listed
- Power and DMX in/thru connections for easy setup
- User-friendly control interface with multiple modes and fixture settings

PHYSICAL

- Rugged die-cast all-metal housing
- Easy access slots for secondary lenses and standard 190mm PAR accessories
- Available in black, white, silver grey or custom colours
- Hanging yoke is standard. Optional yoke/floor stand available

ELECTRICAL

- 100VAC to 240VAC 50/60 Hz universal power input
Max. consumption 110W 0.48A at 230V
- Neutrik power in and thru connections (dry-location version)
- Up to 10 fixtures may be linked via power in/thru connectors per 15A circuit using 1.0mm² cables as supplied
- Requires power from a non-dim source

LED*

- 50,000 hour LED life (50,000 hours to 70% intensity)
- 40 Luxeon® Rebel 2.5W LED emitters

* See additional LED notes on page three

COLOUR

- Exclusive x7 *Color System*™ seven-colour LED array
- Broad spectrum colour interacts seamlessly with conventional sources
- Beautifully illuminates skin tones and other objects for natural appearance and high color rendering
- Exclusive optional red-shift option emulates tungsten dimming performance characteristics

OPTICAL

- Primary field angle of 17°
- Secondary lenses available for multiple beam spread options
- Each luminaire ships with a 25° (7410K1010) round lens; additional lenses must be ordered separately
- Refer to page three for secondary lenses available

CONTROL

- DMX512 in and thru via 5-pin XLR connectors
- Multiple control options including RGB, strobe, and console-free Master/Slave mode
- See DMX Control Table for additional information
- 15-bit virtual dimming engine provides smooth, high quality theatrical fades
- RDM functionality for address and setting changes.

THERMAL

- Ambient operating temperature from -20°C to +40°C
- Active electronic thermal management for droop-free operation
- Convection cooled for use in acoustically sensitive installations
- Luminaire is designed for continuous operation up to +40°C ambient temperature and requires free airflow around fixture housing

ADDITIONAL ORDERING INFORMATION

Power Thru jumper cables

Note: Connect to fixture's output (thru) connector to provide link to successive fixtures.

PART NO.	DESCRIPTION
7401B7008	1.5m PowerCon™ to bare-end power input cable 3x1mm ² (Spare)
7410K1101	1m PowerCon™ to bare-end power thru cable 3x1mm ²
7410K1102	1m PowerCon™ to PowerCon™ fixture to fixture jumper cable 3x1mm ²
7410K1103	2m PowerCon™ to PowerCon™ fixture to fixture jumper cable 3x1mm ²
7410K1104	5m PowerCon™ to PowerCon™ fixture to fixture jumper cable 3x1mm ²
7410K1105	1m fixture to fixture twin jumper cable with both power and DMX connectors
7410K1106	2m fixture to fixture twin jumper cable with both power and DMX connectors
7410K1107	5m fixture to fixture twin jumper cable with both power and DMX connector

Accessories

PART NO.	DESCRIPTION:
7410K1003	D40 Floorstanding Yoke Combo, Black
7410K1004	D40 Floorstanding Yoke Combo, White
7410K1005	D40 Floorstanding Yoke Combo, Silver Grey
PSF1095	Barn door, Short, Black*
7061A3007	Colour Frame, Black**
7061A3007-1	Colour Frame, White**
PSF1028	Egg Crate Louvre, Black
PSF1022	Top Hat with 76mm Tube, Black
PSF1022-1	Top Hat with 76mm Tube, White
PSF1023	Top Hat with 153mm Tube, Black
PSF1023-1	Top Hat with 153mm Tube, White
PSF1027	Half Hat with 153mm Tube, Black
PSF1027-1	Half Hat with 153mm Tube, White

*Use as a (flexible) top hat to diminish aperture glare. Not suitable for beam shaping.

**For use with optional diffusion media

Selador Desire™ Series

ADDITIONAL ORDERING INFORMATION

Secondary Lens Options

DESCRIPTION: The following lenses are cut for D40 luminaires and create round, linear or oblong field patterns as described below. These lenses are *not* for use in Selador® Classic (Vivid™, Lustr®, Paletta™, etc.) fixtures. Frame included.

PART NO.	DESCRIPTION
Narrow Linear Field	
Linear lenses (same material as used with Selador Classic) may be combined to create desired field size, i.e. 40° X 60°	
7410K1017	Ø190mm 20° lens (linear field)
7410K1018	Ø190mm 30° lens (linear field)
7410K1019	Ø190mm 40° lens (linear field)
7410K1020	Ø190mm 60° lens (linear field)
7410K1021	Ø190mm 80° lens (linear field)
Round Field	
7410K1010	190x190mm 25° lens (round field)
7410K1011	190x190mm 35° lens (round field)
7410K1012	190x190mm 45° lens (round field)
7410K1013	190x190mm 75° lens (round field)
Oval (oblong) Field	
7410K1014	Ø190mm 20° x 40° lens (oval field)
7410K1015	Ø190mm 30° x 70° lens (oval field)
7410K1016	Ø190mm 35° x 80° lens (oval field)

Typical Lens Field Profiles

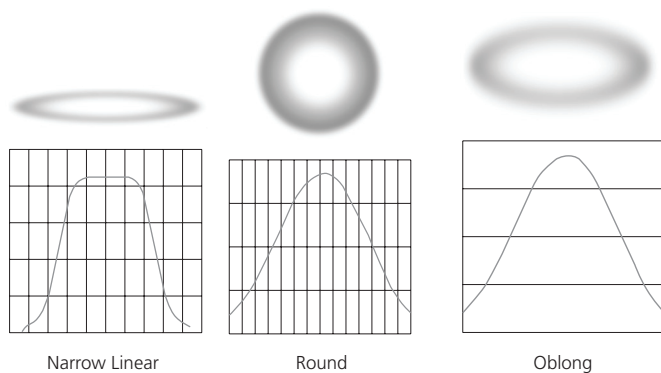

Power Consumption at Full Intensity

MODEL	VOLTAGE (V)	CURRENT (A)	WATTS
D40 - all variants	230	0.48	110

NOTES ABOUT LED LUMINAIRES

Colour Rendering Index (CRI)

The previous colour rendition method developed at the time when fluorescent light sources was introduced. Generally not applicable for measuring LED light sources.

Colour Quality Scale (CQS)

A new colour rendition method developed by NIST (The National Institute of Standards and Technology) in the US. Developed to better account for LED specifics.

CRI AND CQS RATINGS

Desire fixtures were evaluated for CRI and CQS performance using measured output spectrum and optimized mix solutions for a best spectral match to black body sources at 3200K and 5600K.

Fixture	CRI	CQS	Color Fidelity	Duv
D40 Vivid™ at 3200K	87	89	89	0.000
D40 Vivid at 5600K	90	92	92	0.000
D40 Lustr+™ at 3200K	86	88	88	0.000
D40 Lustr+ at 5600K	93	92	90	0.000
D40 Studio HD™ at 3200K	89	90	91	0.000
D40 Studio HD at 5600K	92	94	94	0.000
D40 Studio Daylight™ at 5600K	71	70	69	0.001
D40 Studio Tungsten™ at 3000K	86	86	86	0.001

All D40 luminaire versions provide excellent colour rendering to the eye, particularly at higher colour temperature settings such as 5600K. In most cases the Duv is 0.000. A Duv rating of 0.000 indicates that the color mix used is exactly on the black body line, with no green or magenta tint.

Typical LED source characteristics

All LED sources experience some lessening of light output and some colour shift over time. LED output will vary with thermal conditions. With typical usage, a Selador luminaire will still achieve 70% of its initial output after 50,000 hours. In individual situations, LEDs will be used for different durations and at different levels. This can eventually lead to minor alterations in colour performance, necessitating slight adjustment to presets, cues or programs.

Selador Desire™ Series

CONTROL OPTIONS

User settings on D40 fixtures allow multiple operational modes and settings for either console operation via DMX protocol or stand-alone operation. The expanded LCD display provides easy navigation to all possible settings and options. Some of the setting options are:

- Multiple DMX choices ranging from a simple RGB profile – which effectively controls all seven LED colors via three channels – to nine-channel direct colour and intensity control.
- Multiple dimming curve options
- Preset colours and effects for stand-alone (no console required) operation
- White point selection – white light and colour behavior based on a specific colour temperature white light, i.e. 3200K, 5600K, etc.
- Loss of data behavior options – instant off, hold last look for two minutes, etc.
- Output modes – three output options that offer user control of maximum output versus maximum color consistency

See the user manual for a complete explanation of all of the control settings and options for the D40.

Quick Setups

To assist in managing the numerous control and fixture behavior choices, five combinations of operational settings are available to quickly get started. These settings are specifically created for different use situations and are easily accessible at the fixture display. Each setting can then be modified as required to take advantage of all of the possible control features.

Setting Title	Profile	Description	Typical Features*
General	Direct	Factory Default: For general purpose use including interior architectural applications	<ul style="list-style-type: none"> • Standard dimming curve • Regulated output for colour consistency • 3200K white point setting
Stage	HSI Plus 7 Enabled	Theatrical lighting: Duplicates the colour and dimming behavior of tungsten stage lighting fixtures.	<ul style="list-style-type: none"> • Incandescent dimming curve • Regulated output for colour consistency • Red shift enabled • 3250K white point setting
XT Arch	HSI	Exterior Architectural lighting: Provides a high degree of color consistency in high ambient temperature environments.	<ul style="list-style-type: none"> • Standard dimming curve • Protected output • 3200 white point setting
Impact	RGB	Event lighting: Enables quickest response, simple RGB control and strobe channel for maximum effect usage	<ul style="list-style-type: none"> • Quick dimming curve • Boost mode for maximum intensity • Red shift disabled • 5600K white point setting
Studio	Studio	Video/film lighting: Enables three parameter control of white light via DMX from console or from fixture display – no console required	<ul style="list-style-type: none"> • Linear dimming curve • Regulated output mode for colour consistency

*See User Manual for complete list of features for each Quick Setup

CONTROL OPTIONS

DMX Input Channel Profiles

DMX Profile	DMX Channels	Channel Assignments	Notes
RGB	5 (Ch. 4 not used)	1 – Red 2 – Green 3 – Blue 4 – n/a 5 – Strobe	Effectively addresses all seven colours via three channels of control. RGB profile will produce medium quality colour cross-fades
Direct	9	1 – Red 2 – Orange (white if Lustr+) 3 – Amber 4 – Green 5 – Cyan 6 – Blue 7 – Indigo 8 – Intensity 9 – Strobe	Direct control of each individual colour with a separate master intensity channel. Colour calibration of LEDs is not active in this mode. The nine-channel profile will produce the highest quality colour cross-fades.
HSI	5	1 – Hue (coarse) 2 – Hue (fine) 3 – Saturation 4 – Intensity 5 – Strobe	High resolution hue (two-channels), saturation, and intensity control. HSI mode will produce arbitrary colour cross-fades around the color space.
HSIC	6	1 – Hue (coarse) 2 – Hue (fine) 3 – Saturation 4 – Intensity 5 – Strobe 6 – Colour Point (CCT)	High-resolution hue, saturation and intensity control as above, with the addition of a colour point channel to adjust the colour temperature of the fixture in both white light and color. Colour cross-fade performance is the same as EHSI.
Studio	3	1 – Intensity 2 – Colour Point (CCT) 3 – Tint	Controls fixture as a white light unit. If no DMX, i.e. console input, is present, fixture can be adjusted for these three parameters on the U/I at the back of the unit.

Additional profile options

Plus 7	Seven additional colour control channels are available in RGB, HSI, HSIC and Studio input profile settings. For example HSI with 'Plus 7' enabled becomes a 14-channel profile:	1 – Hue (coarse) 2 – Hue (fine) 3 – Saturation 4 – Intensity 5 – Strobe 6 – n/a 7 – Plus Seven Control on/off 8 – Red 9 – Orange (white if Lustr+) 10 – Amber 11 – Green 12 – Cyan 13 – Blue 14 – Indigo	The desired colour and intensity is achieved by using the HSI or RGB channels. Placing channel seven at a value over 51% gives the fixture a 14-channel profile. Channels 8-14 represent the native colours of the fixture and allow the operator to adjust individual colour channels to fine tune the colour output.
Strobe	Variable strobe control. 0% is no strobe. The fixture output will strobe more rapidly as the strobe channel value approaches 100%.		

Selador Desire™ Series

PHOTOMETRICS

D40 Vivid™

Mode	Degree	Candela	Field Lumens	Beam Lumens	Lumens Per Watt
Boost - Cold	17°	101,900	2,540	1,200	26.7
Regulated	17°	87,200	2,150	1,020	26.5

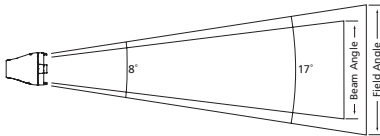

Throw Distance (d)	3.0m	4.6m	6.1m	7.6m	97m
Field Diameter	0.9m	1.4m	1.9m	2.3m	-
Illuminance (lux)	10,968	4,875	2,742	1,755	10.76

Conversions: For Feet, multiply meters by 3.2808
 For footcandles divide lux by 10.764
 For Field diameter at any distance, multiply distance by .308
 For Beam diameter at any distance, multiply distance by .145

Colour Temperature	CQS	CRI
3200K	89	87
5600K	92	90

Cosine Candela Plot

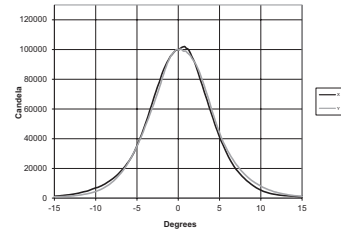

Iso-Illuminance Diagram (Flat Surface Distribution)

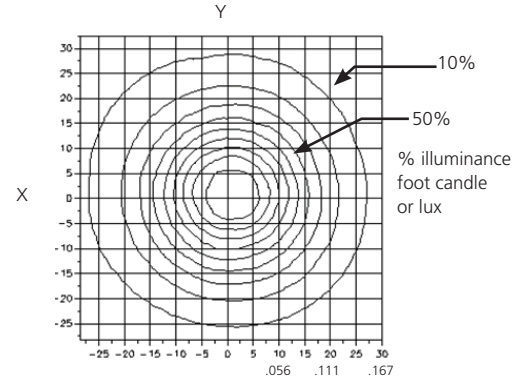

D40 Lustr+™

Mode	Degree	Candela	Field Lumens	Beam Lumens	Lumens Per Watt
Boost - Cold	17°	121,500	2,980	1,450	30.3
Regulated	17°	109,100	2,680	1,300	29.8

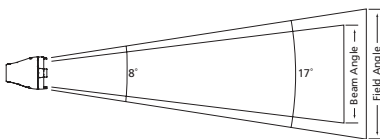

Throw Distance (d)	3.0m	4.6m	6.1m	7.6m	106m
Field Diameter	0.9m	1.4m	1.8m	2.3m	-
Illuminance (lux)	13,078	5,813	3,270	2,093	10.76

Conversions: For Feet, multiply meters by 3.2808
 For footcandles divide lux by 10.764
 For Field diameter at any distance, multiply distance by .301
 For Beam diameter at any distance, multiply distance by .145

Colour Temperature	CQS	CRI
3200K	88	86
5600K	92	93

Cosine Candela Plot

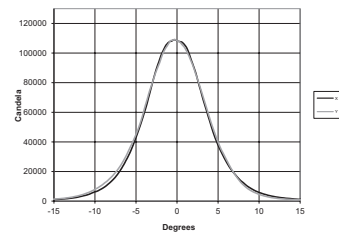

Iso-Illuminance Diagram (Flat Surface Distribution)

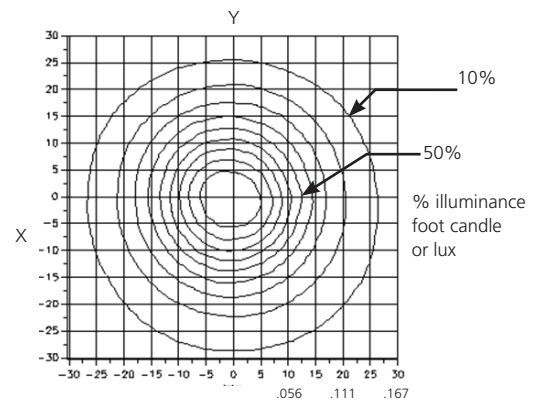

Selador Desire™ Series

PHOTOMETRICS

D40 Fire™

Mode	Degree	Candela	Field Lumens	Beam Lumens	Lumens Per Watt
Boost - cold	17°	94,900	2,540	1,200	28.7
Regulated - cold	17°	82,500	2,220	1,040	27.7

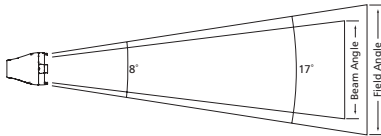

Throw Distance (d)	3.0m	4.6m	6.1m	7.6m	93m
Field Diameter	1.0m	1.5m	1.9m	2.4m	-
Illuminance (lux)	10,215	4,540	2,554	1,634	10.76

Conversions: For Feet, multiply meters by 3.2808
 For footcandles divide lux by 10.764
 For Field diameter at any distance, multiply distance by .318
 For Beam diameter at any distance, multiply distance by .148

Cosine Candela Plot

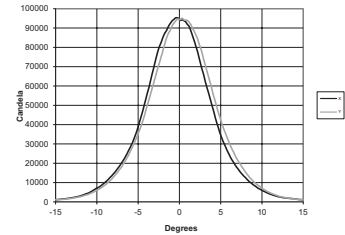

Iso-Illuminance Diagram (Flat Surface Distribution)

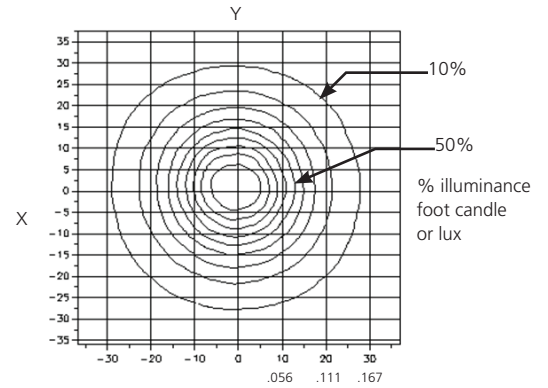

D40 Ice™

Mode	Degree	Candela	Field Lumens	Beam Lumens	Lumens Per Watt
Boost - cold	17°	70,900	1,830	890	18.1
Regulated - cold	17°	63,200	1,630	790	18.0

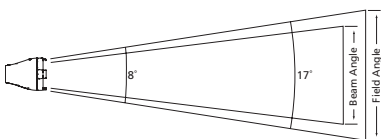

Throw Distance (d)	3.0m	4.6m	6.1m	9.1m	81m
Field Diameter	0.9m	1.4m	1.9m	2.8m	-
Illuminance (lux)	7,632	3,392	1,908	848	10.76

Conversions: For Feet, multiply meters by 3.2808
 For footcandles divide lux by 10.764
 For Field diameter at any distance, multiply distance by .310
 For Beam diameter at any distance, multiply distance by .147

Cosine Candela Plot

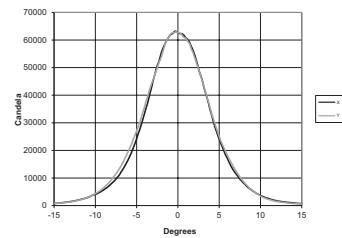

Iso-Illuminance Diagram (Flat Surface Distribution)

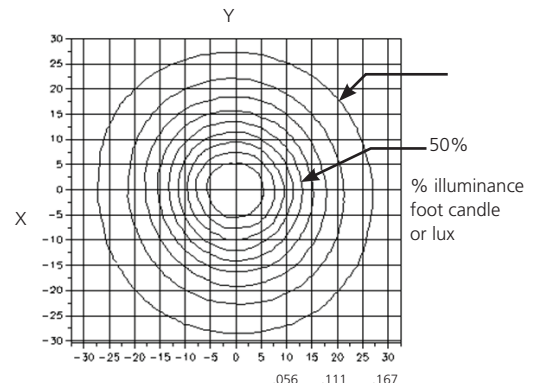

Throw Distance Multiplier (TDM)

To determine the distance from the center of the beam (Origin) to a certain illuminance level at a particular distance, multiply the desired throw distance by the TDM desired on the Iso-Illuminance diagram.

Throw Distance (TD) x Throw Distance Multiplier (TDM) = Distance from the Origin (Dfo) (distance from the center of the beam)

Example: 10m (TD) x 0.047 (TDM) = 0.470m from center of beam (Dfo)

For illumination with any lamp, multiply the candlepower of a beam spread by the multiplying factor (mf) shown for that lamp.

To determine illumination in lux or footcandles at any throw distance, divide candlepower by distance squared.

PHYSICAL

Selador D40 Weights and Dimensions

WEIGHT*	SHIPPING WEIGHT
Kg	Kg
6.4	7.8

* Does not include mounting hardware

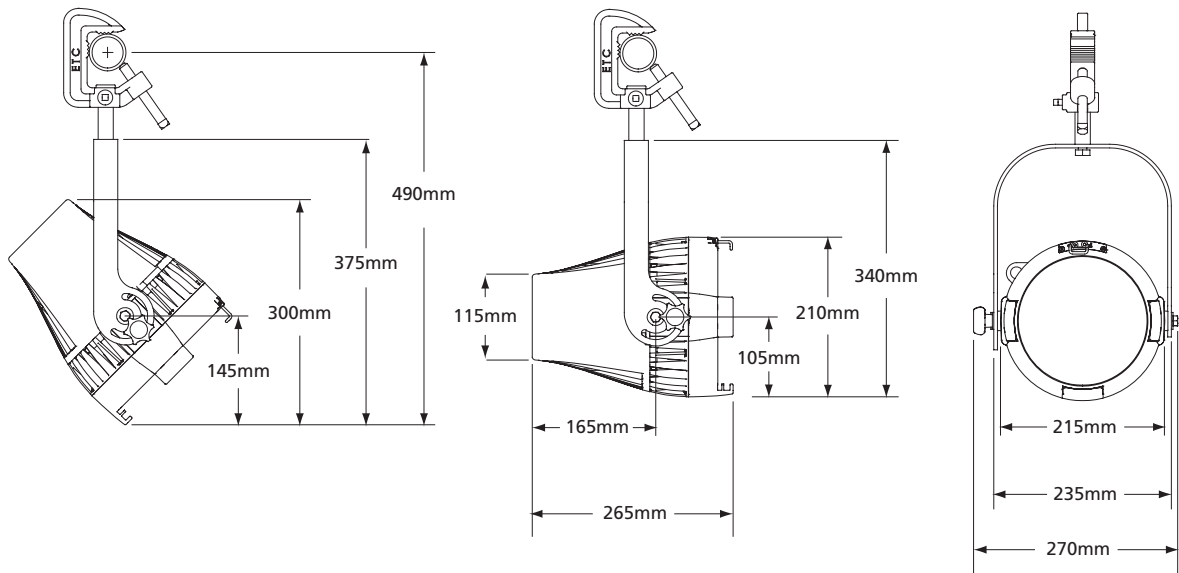

AVAILABLE FROM

Corporate Headquarters • 3031 Pleasant View Rd, PO Box 620979, Middleton WI 53562 0979 USA • Tel +1 608 831 4116 • Fax +1 608 836 1736

London, UK • Unit 26-28, Victoria Industrial Estate, Victoria Road, London W3 6UU, UK • Tel +44 (0)20 8896 1000 • Fax +44 (0)20 8896 2000

Rome, IT • Via Pieve Torina, 48, 00156 Rome, Italy • Tel +39 (06) 32 111 683 • Fax +44 (0)20 8752 8486

Holzkirchen, DE • Ohmstrasse 3, 83607 Holzkirchen, Germany • Tel +49 (80 24) 47 00-0 • Fax +49 (80 24) 47 00-3 00

Hong Kong • Room 1801, 18/F, Tower 1 Phase 1, Enterprise Square, 9 Sheung Yuet Road, Kowloon Bay, Kowloon, Hong Kong • Tel +852 2799 1220 • Fax +852 2799 9325

Web • www.etconnect.com • Copyright©2012 ETC. All Rights Reserved. All product information and specifications subject to change. 7410L1001-GB Rev. E 02/12

This product is protected by one or more of the following U.S. Patents: 6,016,038, 6,150,774, 6,788,011, 6,806,659, 6,683,423 and 7,023,543