

## Polaris 1000W

A compact 1000W studio fresnel, suitable for key and backlight in smaller studios. Manual and pole operated versions available. Polaris has a high quality optical design to give excellent smooth beam over a wide range of beam angles.

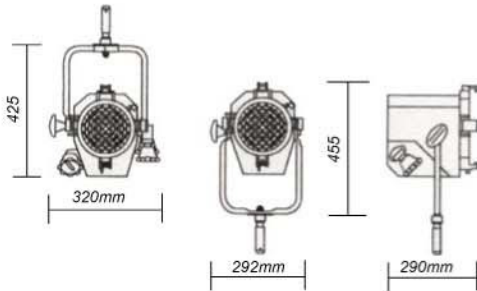

### Ordering Information

- 26280 Polaris 1kW MO supplied with barndoor, colour frame and stirrup with head-mounted toggle switch with 7m cable BE, 29mm spigot
- 26290 Polaris 1kW PO supplied with barndoor, colour frame and stirrup, head-mounted toggle switch with 7m cable BE, 29mm spigot

### Accessories

- 28110 4 leaf barndoor
- 28086 colour frame
- 28305 scrim set (one double scrim, one single scrim, one half double scrim, one half single scrim)
- 82002 safety bond, 50kg
- 82012 hook clamp for 29mm spigot (50mmØ barrel)
- 82013 hook clamp for 29mm spigot (30/50mmØ barrel, SWL 50kg)

### Operational Data

Weight (head & stirrup)	6.0kg
Packed weight	10.5kg
Packed volume	0.07m <sup>3</sup>
Lens diameter	150mm
Filter cut size diameter	230mm
Mounting	29mm spigot (not 26280E)
Range	9° to 59.5°
Safety	EN60 598 2-17

### Lamp Data

Lamp code	CP40 1000W
LCL (mm)	63.5
Base	G22
Lumens	26,000
Rated life hours (H)	250
Colour temp. (K)	3200

### Photometric Data



Typical performance based on CP40 1000W lamp

Spot (9°)	6	9	12
Throw (m)	0.94	1.41	1.88
Beam Ø (m)	3416	1518	854
Lux			
Flood (59.5°)	3	6	9
Throw (m)	3.3	6.8	10.2
Beam Ø (m)	1988	497	220
Lux			

Compact 2000/2500W studio fresnel, the Castor is popular as a general purpose key or backlight in studios and on location. Manual and pole operated versions available.

### Ordering Information

- 26300 Castor 2kW MO supplied with barndoor, colour frame and stirrup with head-mounted rotary switch with 7m cable BE, 29mm spigot
- 26310 Castor 2kW PO supplied with barndoor, colour frame and stirrup, with head-mounted rotary switch with 7m cable BE, 29mm spigot
- Accessories**
- 28070 4 leaf barndoor
- 28093 colour frame
- 28306 scrim set (one double scrim, one single scrim, one half double scrim, one half single scrim)
- 82002 safety bond, 50kg
- 82012 hook clamp for 29mm spigot (50mmØ barrel)
- 82013 hook clamp for 29mm spigot (30/50mmØ barrel, SWL 50kg)

### Operational Data

	Castor 1.25/2.5kW	Castor 2kW
Weight (head & stirrup)	13.5kg	13.5kg
Packed weight	17.5kg	17.5kg
Packed volume	0.118m <sup>3</sup>	0.118m <sup>3</sup>
Lens diameter	250mm	250mm
Filter cut size diameter	320mm	320mm
Mounting	29mm spigot (not 26300E)	
Range	9° to 49°	8.5° to 45°
Safety	EN60 598 2-17	

### Lamp Data

Lamp code	CP41-2000W	CP94-2500W	CP30-1250/2500W
LCL (mm)	127	127	127
Base	G38	G38	GX38q
Lumens	54,000	67,500	27,000/56,000
Rated life hours (H)	400	400	300
Colour temp. (K)	3200	3200	3200

## Castor 2000W

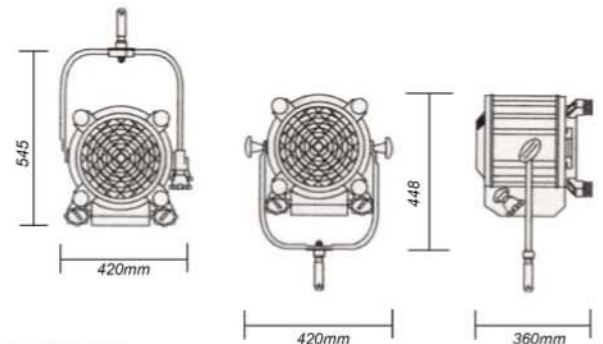

### Photometric Data



Typical performance based on CP41 2000W lamp

Spot (8.5°)	10	15	20
Throw (m)	1.48	2.22	2.97
Beam Ø (m)	3470	1542	867
Lux			
Flood (45.5°)	5	10	15
Throw (m)	4.2	8.3	12.5
Beam Ø (m)	1972	493	220
Lux			